

Certificate No.: 7A032203E



Certificate of Compliance

Applicant : **VIVOTEK INC.**

6F, No. 192, Lien-Cheng Rd., Chung-Ho City, Taipei County,
Taiwan, R.O.C.

Equipment : **Video Server**

Model No. : **VS7100**



Interocean EMC Technology Corp.

No.5-2 Lin 1 Tin-Fu Tsun Lin-Kou Hsiang, Taipei County, Taiwan 244

HEREBY CERTIFY THAT:

We, Interocean EMC Technology Corp., Declare under our sole responsibility, that the equipment described below Complies with the equipments of the EUROPEAN COUNCIL DIRECTIVE (2004/108/EC)

Emission Measurement Standard

EN 55022: 2006 (CLASS B)

EN 61000-3-2: 2000+A2: 2005

EN 61000-3-3: 1995+A1: 2001

AS/NZS CISPR 22: 2006 (CLASS B)

Immunity Measurement Standard

EN 55024:1998+A1: 2001+A2: 2003

Issued By:

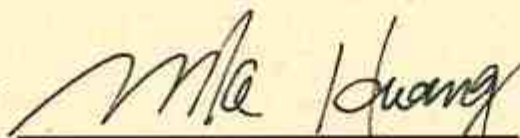
Mike Huang / EMC Manager

Date: April 27, 2007



Declaration of Conformity



We. Manufacturer/Importer

VIVOTEK INC.

6F, No. 192, Lien-Cheng Rd., Chung-Ho City, Taipei County, Taiwan, R.O.C

declare that the product

Video Server

VS7100

Is in conformity with

(Reference to the specification under which conformity is declared)

in accordance with 2004/108/EC-EMC Directive

- | | | | |
|--|---|--|--|
| <input type="checkbox"/> EN55011 | Limits and methods of measurement of radio disturbance characteristics of industrial, scientific and medical (ISM) high frequency equipment | <input checked="" type="checkbox"/> EN61000-3-2 | Disturbances in supply systems caused by household appliances and similar electrical equipment "Harmonics" |
| <input type="checkbox"/> EN55013 | Limits and methods of measurement of radio disturbance characteristics of broadcast receivers and associated equipment | <input checked="" type="checkbox"/> EN61000-3-3 | Disturbances in supply systems caused by household appliances and similar electrical equipment "Voltage fluctuations" |
| <input type="checkbox"/> EN55014-1 | Electromagnetic compatibility – Requirements for household appliances, electric tools and similar apparatus – Part 1: Emission – Product family standard | <input type="checkbox"/> EN61000-6-1 | Electromagnetic compatibility (EMC) – Part 6-1: Generic standards – Immunity for residential, commercial and light-industrial environments |
| <input type="checkbox"/> EN55015 | Limits and methods of measurement of radio disturbance characteristics of fluorescent lamps and luminaries | <input type="checkbox"/> EN61000-6-2 | Electromagnetic compatibility (EMC) – Part 6-2: Generic standards – Immunity for industrial environments |
| <input type="checkbox"/> EN55020 | Immunity from radio interference of broadcast receivers and associated equipment | <input type="checkbox"/> EN61000-6-3 | Electromagnetic compatibility (EMC) – Part 6-3: Generic standards – Emission standard for residential, commercial and light industrial environments |
| <input checked="" type="checkbox"/> EN55022 | Limits and methods of measurement of radio disturbance characteristics of information technology equipment | <input type="checkbox"/> EN61000-6-4 | Electromagnetic compatibility (EMC) – Part 6-4: Generic standards – Emission standard for industrial environments |
| <input type="checkbox"/> EN50130-4 | Alarm systems – Part 4: Electromagnetic compatibility – Product family standard: Immunity requirements for components of fire, intruder and social alarm systems. | <input type="checkbox"/> EN55014-2 | Electromagnetic compatibility – Requirements for household appliances, electric tools and similar apparatus – Part 2: Immunity – Product family standard |
| <input type="checkbox"/> EN62040-2 | Uninterruptible Power Systems (UPS) – Part 2: Electromagnetic compatibility (EMC) requirements. | <input type="checkbox"/> EN60601-1-2 | Medical Electrical Equipment |
| <input type="checkbox"/> EN61204-3 | Low voltage power supplies, d.c. output Part 3: Electromagnetic compatibility (EMC) | <input checked="" type="checkbox"/> EN55024 | Information technology equipment – Immunity characteristics – Limits and methods of measurement |

Manufacturer/Importer

Signature: _____

(stamp)

Date: _____

Name: _____

Test Report

(Declaration of Conformity)

for

Electromagnetic Compatibility

of

E.U.T.: Video Server

Trade Name: Vivotek

Model Number: VS7100

Prepared for

VIVOTEK INC.

6F, No. 192, Lien-Cheng Rd., Chung-Ho City, Taipei County,
Taiwan, R.O.C.

TEL: +886 2 8245 5282

FAX: +886 2 8245 5532

Prepared by

Interocean EMC Technology Corp.

244 No.5-2, Lin 1, Tin-Fu Tsun, Lin-Kou Hsiang,
Taipei County, Taiwan, R.O.C.

TEL.: +886 2 2600 6861

FAX.: +886 2 2600 6859

Remark:

The test report consists of **56** pages in total. It shall not be reproduced except in full, without the written approval of IETC. This document may be altered or revised by IETC only, and shall be noted in the revision section of the document. The test results in the report only to the tested sample.

Table of Contents

1	General Information	6
1.1	Description of Equipment Under Test	6
1.2	Details of Tested Supporting System	7
1.3	Test Facility	9
1.4	Measurement Uncertainty	10
1.5	Measured Mode	11
1.6	Configuration of EUT Setup	11
1.7	Test Step of EUT	11
2	Power Line Conducted Emission Measurement	12
2.1	Instrument	12
2.2	Block Diagram of Test Configuration	12
2.3	Conducted Limit	13
2.4	Instrument configuration	13
2.5	Configuration of Measurement	13
2.6	Test Result	13
3	Telecommunication ports Conducted Emission Measurement	16
3.1	Instrument	16
3.2	Block Diagram of Test Configuration	16
3.3	Conducted Limit (Telecommunication ports)	17
3.4	Instrument configuration	17
3.5	Configuration of Measurement	18
3.6	Test Result	18
4	Radiated Emission Measurement	20
4.1	Instrument	20
4.2	Block Diagram of Test Configuration	20
4.3	Radiated Limit	21
4.4	Instrument configuration	21
4.5	Configuration of Measurement	21
4.6	Test Result	21
5	Harmonic Current Emission Measurement (EN 61000-3-2)	24
5.1	Instrument	24
5.2	Block Diagram of Test Configuration	24
5.3	Test Limit	25
5.4	Configuration of Measurement	25
5.5	Test Result	25

6	Voltage Fluctuations and Flicker Measurement (EN 61000-3-3)	29
6.1	Instrument	29
6.2	Block Diagram of Test Configuration	29
6.3	Test Limit	30
6.4	Configuration of Measurement	30
6.5	Test Result	30
7	Electrostatic Discharge Immunity Test (IEC 61000-4-2)	32
7.1	Instrument	32
7.2	Block Diagram of Test Configuration	32
7.3	Test Levels & Performance Criterion	32
7.4	Test Requirement	33
7.5	Configuration of Measurement	33
7.6	Test Result	33
8	Radio-frequency, Electromagnetic field Immunity Test (IEC 61000-4-3)	34
8.1	Instrument	34
8.2	Block Diagram of Test Configuration	34
8.3	Test Levels & Performance Criterion	34
8.4	Test Requirement	35
8.5	Configuration of Measurement	35
8.6	Test Result	35
9	Electrical Fast Transient/Burst Immunity Test (IEC 61000-4-4)	36
9.1	Instrument	36
9.2	Block Diagram of Test Configuration	36
9.3	Test Levels & Performance Criterion	36
9.4	Test Requirement	37
9.5	Configuration of Measurement	37
9.6	Test Result	37
10	Surge Immunity Test (IEC 61000-4-5)	38
10.1	Instrument	38
10.2	Block Diagram of Test Configuration	38
10.3	Test Levels & Performance Criterion	38
10.4	Test Requirement	39
10.5	Configuration of Measurement	39
10.6	Test Result	39

11	Radio-frequency, Conducted Disturbances Immunity Test (IEC 61000-4-6)	40
11.1	Instrument	40
11.2	Block Diagram of Test Configuration	40
11.3	Test Levels	40
11.4	Test Requirement	41
11.5	Configuration of Measurement	41
11.6	Test Result	41
12	Power frequency magnetic field immunity test (IEC 61000-4-8)	42
13	Voltage Dips, Short Interruptions Immunity Test (IEC 61000-4-11)	43
13.1	Instrument	43
13.2	Block Diagram of Test Configuration	43
13.3	Test Levels	44
13.4	Test Requirement	44
13.5	Configuration of Measurement	44
13.6	Test Result	44
14	Photographs of Test	45
14.1	Power Line Conducted Emission Measurement	45
14.2	Radiated Emission Measurement	46
14.3	Harmonic Current & Voltage Fluctuations and Flicker Measurement	47
14.4	Electrostatic Discharge Immunity Test (IEC 61000-4-2)	47
14.5	Radio-Frequency, Electromagnetic Field Immunity Test (IEC 61000-4-3)	48
14.6	Electrical Fast Transient/Burst Immunity Test (IEC 61000-4-4)	49
14.7	Surge Immunity Test (IEC 61000-4-5)	49
14.8	Radio-Frequency, Conducted Disturbances Immunity Test (IEC 61000-4-6)	50
14.9	Voltage Dips, Short Interruptions Immunity Test (IEC 61000-4-11)	50
14.10	Electrostatic Discharge Test Point	51
15	Photographs of EUT	52
16	Photographs of Adapter	55

Verification of Compliance

Applicant: VIVOTEK INC.
Manufacturer: VIVOTEK INC.
EUT Description: Video Server
Model No.: VS7100
Serial No.: N/A
Tested Power Supply: 230Vac, 50Hz
Date of Final Test: Mar. 27, 2007

Measurement Procedures and Standards Used :

Emission:

- EN 55022:2006
- EN 61000-3-2: 2000+A2: 2005
- EN 61000-3-3: 1995+A1: 2001
- AS/NZS CISPR 22: 2006

Immunity:

- EN 55024:1998+A1: 2001+A2: 2003
- IEC 61000-4-2
- IEC 61000-4-3
- IEC 61000-4-4
- IEC 61000-4-5
- IEC 61000-4-6
- IEC 61000-4-8
- IEC 61000-4-11

The device described above was tested by Interocean EMC Technology Corporation to determine the maximum emission levels emanated from the device and severity levels of the device endure and its performance criterion. The measurement results are contained in this test report and Interocean EMC Technology Corp assumes full responsibility for the accuracy and completeness of these measurements. This report shows the EUT is technically compliance with the above official standards.

This report applies to the above sample only and shall not be reproduced in part without written approval of Interocean EMC Technology Corporation.

Report Issued: 2007/04/27

Test Engineer: James Ho ²⁰⁰⁷₀₄₂₇
James Ho

Checked: Benson Tsai ²⁰⁰⁷₀₄₂₇
Benson Tsai

Approved: Mike Huang ²⁰⁰⁷₀₄₂₇
Mike Huang

1 General Information

1.1 Description of Equipment Under Test

Equipment Under Test : Video Server

Model Number : VS7100

Serial Number : N/A

Type of Sample Tested : Proto-type Pre-Production Mass Production

Applicant : **VIVOTEK INC.**
6F, No. 192, Lien-Cheng Rd., Chung-Ho City, Taipei County, Taiwan, R.O.C.

Manufacturer : **VIVOTEK INC.**
6F, No. 192, Lien-Cheng Rd., Chung-Ho City, Taipei County, Taiwan, R.O.C.

Power Supply : ADAPTER:
Model: DSA-0151F-12
Input: 100-240Vac, 50/60Hz, 0.4A
Output: 12Vdc, 1.5A
Power Cable: Non-shielded Un-detachable 1.8 m with core

Date of Receipt Sample : Mar. 21, 2007

Date of Test : Mar. 23~27, 2007

Description of E.U.T. : 1) The EUT is Video Server.
2) The Model Number "VS7100" is representative selected in the test and included in this report.

Product information : Interface/ Port:
1. RJ45 Port *1
RJ45 cable: Non-shielded Detachable 3 m w/o core
2. Audio Port *2
Audio cable: Non-shielded Detachable 1.8 m w/o core
3. Video Port *1
Video cable: Non-shielded Detachable 1.8 m w/o core
4. Power Port *1

1.2 Details of Tested Supporting System

1.2.1 Personal Computer

PC19

Model Number : IBM Think Centre 8175-OVE
Serial Number : 99LBVWV
CPU Speed : Pentium 4 Celeron D 2.8 GHz
EMC Approved : CE, FCC, C-Tick, UL, BSMI: R33026
Manufacturer : IBM
RAM : 256M*1
Hard Disk Driver : 80GB

1.2.2 PS2 Keyboard

KB20

Model Number : Y-SM48
Serial Number : SY506U67236
EMC Approved : FCC DoC, CE, C-Tick, BSMI T51160, VCCI
Manufacturer : LOGITECH
Data Cable : Shielded, Un-detachable, 1.5m

1.2.3 PS2 Mouse

MS23

Model Number : M-SBF83
Serial Number : HCA51802348
EMC Approved : UL, BSMI R41126
Manufacturer : Logitech
Data Cable : Shielded, Un-detachable, 1.8m

1.2.4 Monitor

MT14

Model Number : E71f
Serial Number : P3C041910760
EMC Approved : FCC, CE, BSMI: R31374, UL, TUV
Manufacturer : View Sonic
Data Cable : Shielded, Un-detachable, 1.2m

1.2.5 Modem

MD03

Model Number : 199450042
Serial Number : 211-28E1-1100-3
EMC Approved : N/A
Manufacturer : DATATRONICS
Data Cable : Shielded, Detachable, 1.5m
Power Adapter : Amigo, Model AM-12830A
Non-Shielded, Detachable, 1.8m

1.2.6 Printer

PR03

Model Number : C20SX
Serial Number : DW4Y045545
EMC Approved : BSMI 3902E004
Manufacturer : EPSON
Data Cable : Shielded, Detachable, 1.8m
Power Cord : Non-shielded, Un-detachable, 1.8m

1.2.7 DVD PLAYER

Model Number : DV-S633A
Serial Number : ALMP001192TA
EMC Approved : FCC DoC, CE, VCCI,
Manufacturer : PIONEER

1.3 Test Facility

- Site Description** : OATS 1 OATS 2 OATS 3 OATS 4
- Name of Firm** : Interocean EMC Technology Corp.
- Company web** : <http://www.ietc.com.tw>
- Site 1, 2 Location** : No.5-2, Lin 1, Tin-Fu Tsun, Lin-Kou Hsiang, Taipei County, Taiwan, R.O.C.
- Site 3, 4 Location** : No. 12, Ruei-Shu Valley, Ruei-Ping Tsun, Lin-Kou Hsiang, Taipei County, Taiwan, R.O.C.
- Site Filing** :
- Federal Communication Commissions – USA
Registration No.: 96399 (OATS 1 & 2)
Registration No.: 518958 (OATS 3 & 4)
 - Voluntary Control Council for Interference by Information Technology Equipment (VCCI) – Japan
Registration No. (Conducted Room): C-1094
Registration No. (Conducted Room): T-271
Registration No. (OATS 1): R-1040
Registration No. (OATS 2): R-1041
Registration No. (OATS 3): R-1812
Registration No. (OATS 4): R-1813
 - Industry Canada (IC)
Submission: 113543
 - Japan Electrical Safety & Environment Technology Laboratories (JET)
Registration No.: 04S03-01
- Site Accreditation** :
- Bureau of Standards and Metrology and Inspection (BSMI) – Taiwan, R.O.C.
Accreditation No.:
SL2-IN-E-0026 for CNS13438 / CISPR22
SL2-R1-E-0026 for CNS13439 / CISPR13
SL2-R2-E-0026 for CNS13439 / CISPR13
SL2-A1-E-0026 for CNS13783-1 / CISPR14-1
 - National Voluntary Laboratory Accreditation Program (NVLAP) - USA
Lab Code: 200458-0
 - Nemko AS
Authorization No.: ELA 181A
Authorization No.: ELA 181B
 - Taiwan Accreditation Foundation (TAF)
Accrditation No.: 1113
 - TÜV Rheinland
Certificate No: 10006453

1.3.1 Test Methodology

Both conducted and Radiated Emission Measurement were performed according to the procedures in EN 55022: 2006, AS/NZS CISPR 22: 2006, EN 61000-3-2: 2000+A2: 2005 and EN 61000-3-3:1995+A1: 2001. Radiated Emission Measurement was performed at 10 meters distance from antenna to EUT. All immunity tests were performed according to the procedures in EN 55024:1998+A1: 2001+A2: 2003.



1.4 Measurement Uncertainty

No.	Item	Value
1	Power Line Conducted Emission (Conduction 1)	2.52dB
2	Disturbance Power Emission (Conduction 1)	3.10dB
3	Click disturbances Emission (Conduction 1)	2.40dB
4	Power Line Conducted Emission (Conduction 2)	2.52dB
5	Power Line Conducted Emission (Conduction 3)	2.52dB
6	Power Line Conducted Emission (Conduction 4)	2.52dB
7	Radiated Emission Test (OATS 1)	3.14 dB
8	Radiated Emission Test (OATS 2)	3.14 dB
9	Radiated Emission Test (OATS 3)	3.14 dB
10	Radiated Emission Test (OATS 4)	3.14 dB
11	Radio-frequency, Electromagnetic field Immunity Test (RS)	1.47 dB
12	Radio-frequency, Conducted Disturbances Immunity Test (CS)	2.35 dB

1.5 Measured Mode

1.5.1 The test modes for preliminary test is as following:

- Mode 1: Working Mode

1.5.2 For Emission tests, selected the worst-case **mode 1** after preliminary test for final test.

1.5.3 For EN 61000-3-2, EN 61000-3-3 and Immunity tests, selected the **mode 1** for final test.

1.5.4 The test modes for preliminary test are as following:

- Mode 1: RJ45

1.5.5 After preliminary test, selected the worst cases **mode 1** for final test.

1.6 Configuration of EUT Setup

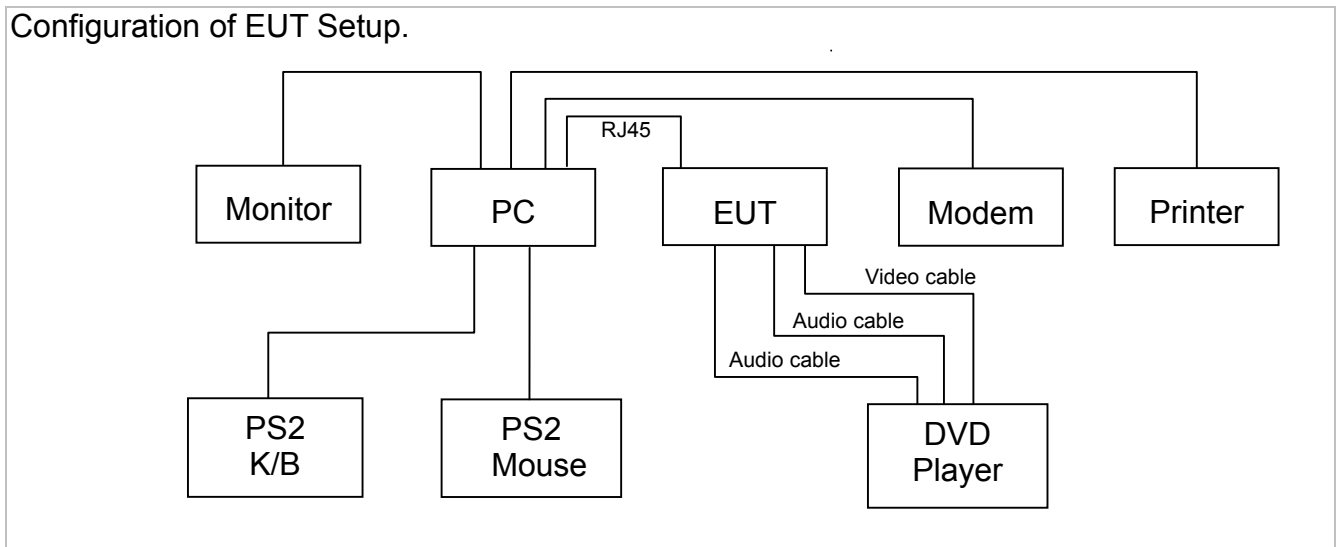

1.7 Test Step of EUT

1.7.1 Setup the EUT and peripheral as above.

1.7.2 Turn on the power of all equipment.

1.7.3 Run EMC program, and on-line with EUT.

1.7.4 Executed the test.

2 Power Line Conducted Emission Measurement

2.1 Instrument

Instrument	Manufacturer	Model	Serial No.	Last Calibration
EMI Test Receiver	Rohde & Schwarz	ESCS30	830245/027	2006/11/03
L.I.S.N.	Schaffner	MN2050D	1597	2006/06/06
L.I.S.N.	Schaffner	MN2050D	1596	2006/06/06
Pulse Limiter	Rohde & Schwarz	ESH3-Z2	830836/026	2006/09/11
RF Cable	MIYAZAKI	5DFB	CBL12	2006/09/11

Note: All instrument upon which need to be calibrated are within calibration period of 1 year.

2.2 Block Diagram of Test Configuration

Configuration of Testing Setup

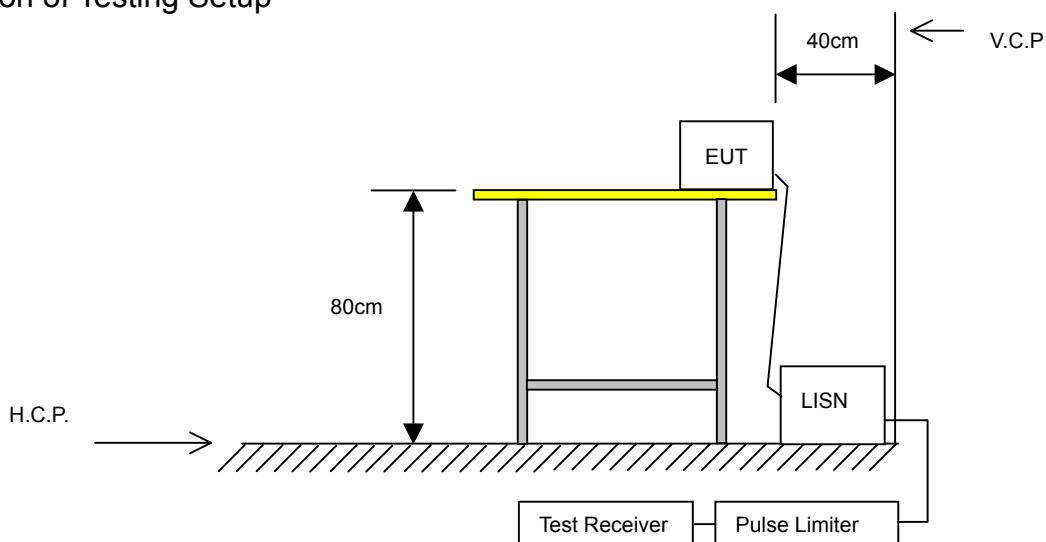

2.3 Conducted Limit

EN 55022 / AS/NZS CISPR 22

Frequency (MHz)	<input type="checkbox"/> Class A (dB μ V)		<input checked="" type="checkbox"/> Class B (dB μ V)	
	Q.P. (Quasi-Peak)	A.V. (Average)	Q.P. (Quasi-Peak)	A.V. (Average)
0.15 ~ 0.50	79	66	66 to 56	56 to 46
0.50 ~ 5.0	73	60	56	46
5.0 ~ 30	73	60	60	50

2.4 Instrument configuration

- 2.4.1 Set the EMI test receiver frequency range from 150 kHz to 30 MHz.
- 2.4.2 Set the EMI test receiver bandwidth at 9kHz.
- 2.4.3 Set the EMI test receiver detector as Quasi-Peak (Q.P.) and Average (AV).

2.5 Configuration of Measurement

- 2.5.1 The EUT was placed on a non-conductive table whose total height equaled 80cm and vertical conducting plane located 40cm to the rear of the EUT.
- 2.5.2 The EUT was connected to the main power through Line Impedance Stabilization Networks (LISN). This setup provided a 50ohm / 50 μ H coupling impedance for the measuring equipment. The auxiliary equipment was also connected to the main power through a LISN that provided a 50ohm/50 μ H coupling impedance with 50ohm termination. (Refer to the block diagram of the test setup and photographs.)
- 2.5.3 The conducted disturbance was measured between the phase lead and the reference ground, and between the neutral lead and reference ground. The initial testing identified the frequency that has the highest disturbance relative to the limit while operating the EUT in typical modes of operation and cable positions in a test setup representative of typical system configuration.
- 2.5.4 The identification of the frequency of highest disturbance with respect to the limit was found by investigating disturbances at a number of significant frequencies. The probable frequency of maximum disturbance had been found and that the associated cable and EUT configuration and mode of operation had been identified.

2.6 Test Result

PASS.

The final test data is shown on as following pages.

Power Line Conducted Test Data

EUT: Video Server	POLARITY: Line
CLIENT: VIVOTEK INC.	DISTANCE:
MODEL: VS7100	Serial No.:
RATING: 230V/50Hz	FILE/DATA#: VIVOTEK INC.emi/6
Temperature: 24.6 °C	OPERATOR: Ivan
Humidity: 60 %	TEST SITE: Conduction2

Frequency (MHz)	Factor (dB)	Meter Reading (dBµV)		Emission Level (dBµV)		Limits(dBµV)		Margin (dB)	
		Quasi-Peak	Average	Quasi-Peak	Average	Quasi-Peak	Average	Quasi-Peak	Average
0.197	0.21	49.45	48.06	49.66	48.27	63.74	53.74	-14.08	-5.47
0.392	0.12	49.97	44.75	50.09	44.87	58.02	48.02	-7.93	-3.15
0.591	0.16	47.60	42.41	47.76	42.57	56.00	46.00	-8.24	-3.43
0.791	0.20	41.58	39.41	41.78	39.61	56.00	46.00	-14.22	-6.39
1.181	0.24	41.00	36.45	41.24	36.69	56.00	46.00	-14.76	-9.31
1.740	0.23	39.71	33.34	39.94	33.57	56.00	46.00	-16.06	-12.43

Remark:
 1. All readings are Quasi-Peak and Average values.
 2. Factor = Insertion Loss + Cable Loss.

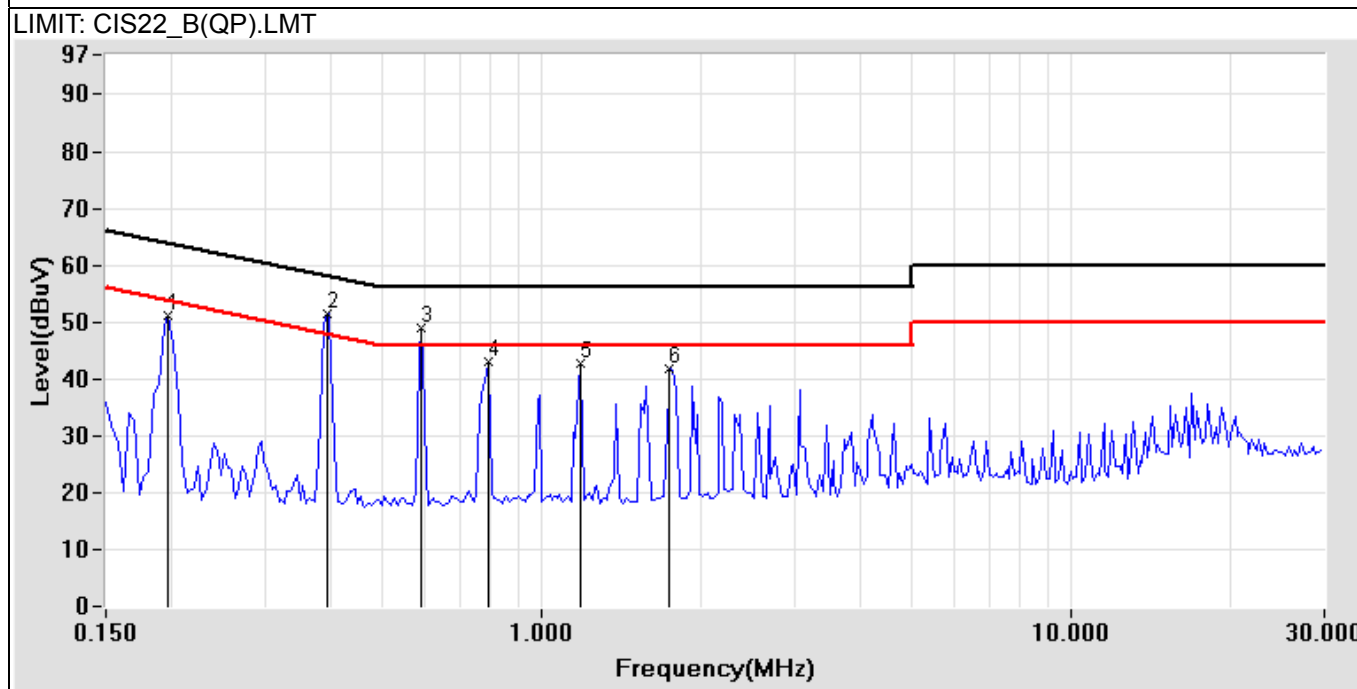

Test Mode: Mode 1: Working Mode

Power Line Conducted Test Data

EUT: Video Server	POLARITY: Neutral
CLIENT: VIVOTEK INC.	DISTANCE:
MODEL: VS7100	Serial No.:
RATING: 230V/50Hz	FILE/DATA#: VIVOTEK INC.emi/7
Temperature: 24.6 °C	OPERATOR: Ivan
Humidity: 60 %	TEST SITE: Conduction2

Frequency (MHz)	Factor (dB)	Meter Reading (dBµV)		Emission Level (dBµV)		Limits (dBµV)		Margin (dB)	
		Quasi-Peak	Average	Quasi-Peak	Average	Quasi-Peak	Average	Quasi-Peak	Average
0.197	0.21	47.06	45.12	47.27	45.33	63.74	53.74	-16.47	-8.41
0.392	0.22	47.24	45.39	47.46	45.61	58.02	48.02	-10.56	-2.41
0.587	0.23	44.58	42.09	44.81	42.32	56.00	46.00	-11.19	-3.68
0.783	0.23	38.04	35.16	38.27	35.39	56.00	46.00	-17.73	-10.61
1.173	0.24	38.68	34.57	38.92	34.81	56.00	46.00	-17.08	-11.19
1.759	0.23	37.93	32.23	38.16	32.46	56.00	46.00	-17.84	-13.54

Remark:
 1. All readings are Quasi-Peak and Average values.
 2. Factor = Insertion Loss + Cable Loss.

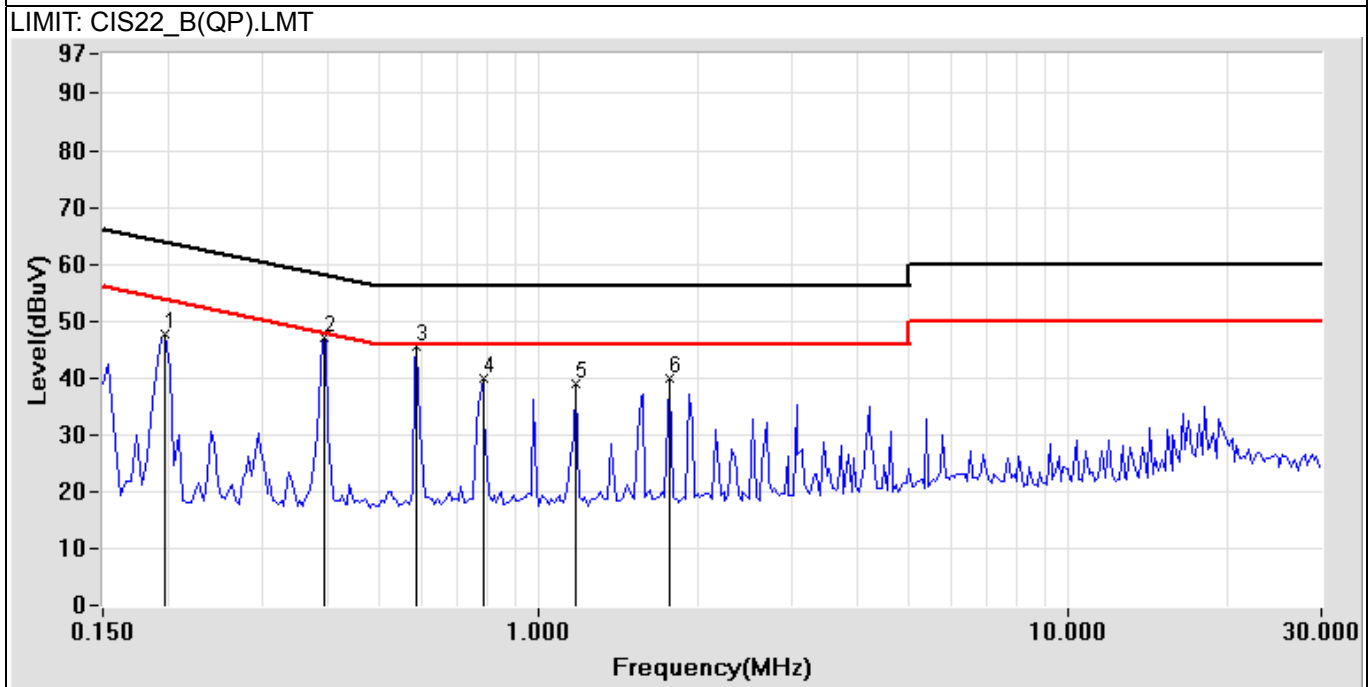

Test Mode: Mode 1: Working Mode

3 Telecommunication ports Conducted Emission Measurement

3.1 Instrument

Instrument	Manufacturer	Model	Serial No.	Last Calibration
EMI Test Receiver	Rohde & Schwarz	ESCS 30	100135	2006/07/31
Pulse Limiter	Rohde & Schwarz	ESH3-Z2	843602/02	2006/09/11
RF Cable	HARBOUR	RG400	CBL04	2006/08/10
ISN	FCC	FCC-TLISN-T4-02	20305	2006/11/07
ISN	FCC	FCC-TLISN-T8-02	20306	2006/11/07
ISN	SCHAFFNER	ISN T400	16591	2007/02/12

Note: All instrument upon which need to calibrated are with calibration period of 1 year.

Instrument	Manufacturer	Model	Serial No.	Last Calibration
Current Probe	SCHAFFNER	SMZ11	18009	2005/06/22

Note: All instrument upon which need to calibrated are with calibration period of 2 year.

3.2 Block Diagram of Test Configuration

Configuration of Instrument Setup.

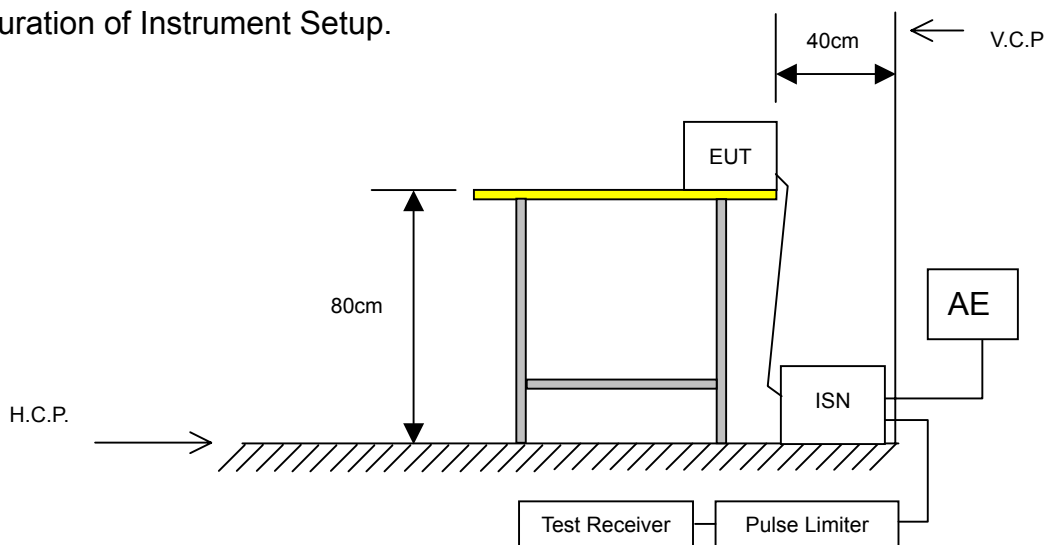

3.3 Conducted Limit (Telecommunication ports)

- Voltage Limits for Class A equipment
- Current Limits for Class A equipment

Frequency range (MHz)	Voltage Limits (dB μ V)		Current Limits (dB μ A)	
	Q.P. (Quasi-Peak)	A.V. (Average)	Q.P. (Quasi-Peak)	A.V. (Average)
0.15 ~ 0.50	97 to 87	84 to 74	53 to 43	40 to 30
0.50 ~ 30	87	74	43	30

NOTE 1 – The limits decrease linearly with the logarithm of the frequency in the range 0.15 MHz to 0.5 MHz.

NOTE 2 – The current and voltage disturbance limits are derived for use with an impedance stabilization network (ISN) which presents a common mode (asymmetric mode) impedance of 150 Ω to the telecommunication port under test (conversion factor is $20 \log_{10} 150 / 1 = 44$ dB).

- Voltage Limits for Class B equipment
- Current Limits for Class B equipment

Frequency range (MHz)	Voltage Limits (dB μ V)		Current Limits (dB μ A)	
	Q.P. (Quasi-Peak)	A.V. (Average)	Q.P. (Quasi-Peak)	A.V. (Average)
0.15 ~ 0.50	84 to 74	74 to 64	40 to 30	30 to 20
0.50 ~ 30	74	64	30	20

NOTE 1 – The limits decrease linearly with the logarithm of the frequency in the range 0.15 MHz to 0.5MHz.

NOTE 2 – The current and voltage disturbance limits are derived for use with an impedance stabilization network (ISN), which presents a common mode (asymmetric mode) impedance of 150 Ω to the telecommunication port under test (conversion factor is $20 \log_{10} 150 / 1 = 44$ dB).

3.4 Instrument configuration

- 3.4.1 Set the EMI test receiver frequency range from 150 kHz to 30 MHz.
- 3.4.2 Set the EMI test receiver bandwidth at 9kHz.
- 3.4.3 Set the EMI test receiver detector as Quasi-Peak (Q.P.) and Average (AV).

3.5 Configuration of Measurement

- 3.5.1 Measurement is made at telecommunication ports using ISN with longitudinal conversion losses (LCL) as defined in EN 55022: 2006 Section 9.6.2.
- 3.5.2 The manufacturer shall demonstrate that the equipment does not exceed the Conducted limits of Telecommunication ports when tested with the ISN according to the cable category specified by the equipment documentation provided to the user.
- 3.5.3 In order to make reliable emission measurements representative of high LAN utilization it is only necessary to create a condition of LAN utilization in excess of 10% and sustain that level for a minimum of 250ms. The content of the test traffic should consist of both periodic and pseudo-random messages in order to emulate realistic types of data transmission (e.g. random: files compressed or encrypted; periodic: uncompressed graphic files, memory dumps, screen updates, disk images).
- a) Voltage measurement at balanced telecommunication ports intended for connection to unscreened balanced pairs. (See EN 55022: 2006 Section 9.6.3.1.)
 - b) Current measurements at balanced telecommunication ports intended for connection to unscreened balanced pairs. (See EN 55022: 2006 Section 9.6.3.2.)
 - c) Voltage measurements at telecommunication ports intended for connection to screened cables or to coaxial cables. (See EN 55022: 2006 Section 9.6.3.3.)
 - d) Current measurements at telecommunication ports intended for connection to screened cables or to coaxial cables. (See EN 55022: 2006 Section 9.6.3.4.)
 - e) Measurements at telecommunication ports intended for connection to cables containing more than four balanced pairs or to unbalanced cables. (See EN 55022: 2006 Section 9.6.3.5.)
- 3.5.4 Recording of measurements
- Of those disturbances above ($L-20\text{dB}$), where L is the limit level in logarithmic units, record at least the disturbance levels and the frequencies of the six highest disturbances from each mains port and each telecommunication port, which comprise the EUT. For the mains port, the current-carrying conductor for each disturbance shall be identified.

3.6 Test Result

PASS.

The final test data is shown on as following pages.

Telecommunication ports Conducted Emission Test Data

EUT: Video Server CLIENT: VIVOTEK INC. MODEL: VS7100 RATING: 230V/50Hz Temperature: 20.0 °C Humidity: 57 %	POLARITY: DISTANCE: Serial No.: FILE/DATA#: VIVOTEK INC.emi/8 OPERATOR: JAMES TEST SITE: Conduction1
---	---

Frequency (MHz)	Factor (dB)	Meter Reading (dBµV)		Emission Level (dBµV)		Limits (dBµV)		Margin (dB)	
		Quasi-Peak	Average	Quasi-Peak	Average	Quasi-Peak	Average	Quasi-Peak	Average
4.310	9.65	47.10	41.86	56.75	51.51	74.00	64.00	-17.25	-12.49
5.759	9.67	47.98	39.88	57.65	49.55	74.00	64.00	-16.35	-14.45
9.357	9.66	47.54	40.74	57.20	50.40	74.00	64.00	-16.80	-13.60
18.244	9.69	53.88	50.81	63.57	60.50	74.00	64.00	-10.43	-3.50
19.709	9.68	50.95	47.77	60.63	57.45	74.00	64.00	-13.37	-6.55
27.158	9.69	46.76	45.05	56.45	54.74	74.00	64.00	-17.55	-9.26

Remark:
 1. All readings are Quasi-Peak and Average values.
 2. Factor = Insertion Loss + Cable Loss.

LIMIT: ISN_V-B(QP).LMT

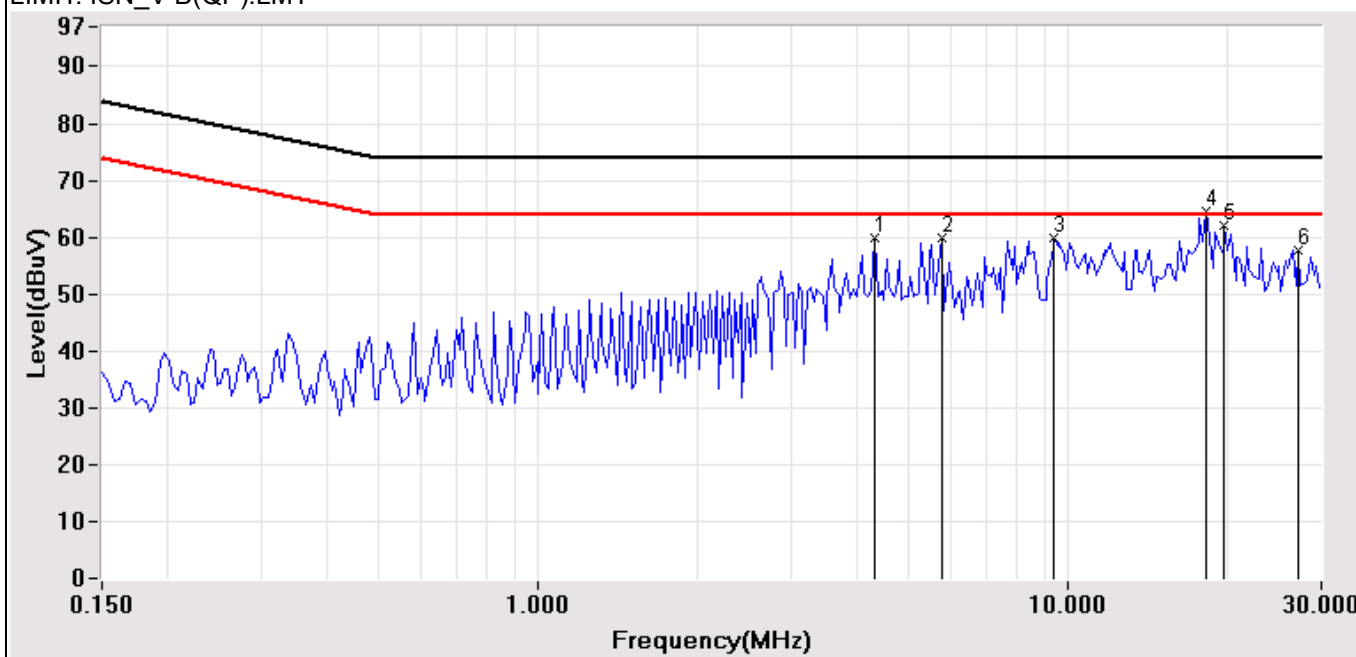

Test Mode: Mode 1: RJ45

4 Radiated Emission Measurement

4.1 Instrument

OATS 1

Instrument	Manufacturer	Model	Serial No.	Last Calibration
EMI Test Receiver	Rohde & Schwarz	ESI7	830154/002	2006/08/09
Bilog Antenna	Schaffner	CBL6111c	2804	2007/03/02
Pre-Amplifier	Schaffner	CPA9231A	3351	2006/12/14
RF Cable	Ultra Link	CBL17	CBL17	2007/02/26

Note: All instrument upon which need to be calibrated are within calibration period of 1 year.

4.2 Block Diagram of Test Configuration

Configuration of Testing Setup

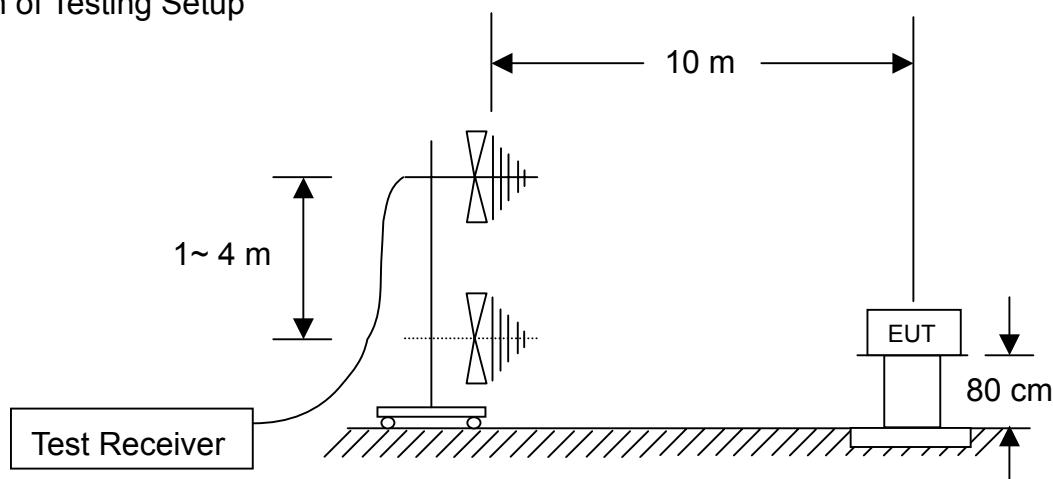

4.3 Radiated Limit

EN 55022 / AS/NZS CISPR 22

Frequency (MHz)	<input type="checkbox"/> Class A	<input checked="" type="checkbox"/> Class B
	Quasi-Peak dB(μ V/m)	Quasi-Peak dB(μ V/m)
30 ~ 230	40.0	30.0
230 ~ 1000	47.0	37.0

4.4 Instrument configuration

- 4.4.1 Set the EMI test receiver frequency range from 30 MHz to 1000 MHz.
- 4.4.2 Set the EMI test receiver bandwidth at 120 kHz.
- 4.4.3 Set the EMI test receiver detector as Quasi-Peak (Q.P.).

4.5 Configuration of Measurement

- 4.5.1 The EUT was placed on a non-conductive table whose total height equaled 80cm. The turntable can rotate 360 degree to determine the position of the maximum emission level.
- 4.5.2 The EUT was set 10 meters away from the receiving antenna that was mounted on a non-conductive mast. The antenna can move up and down between 1 to 4 meters to find out the maximum emission level.
- 4.5.3 The initial testing identified the frequency that has the highest disturbance relative to the limit while operating the EUT in typical modes of operation and cable positions in a test setup representative of typical system configuration.
- 4.5.4 The identification of the frequency of highest emission with respect to the limit was found by investigating emissions at a number of significant frequencies. The probable frequency of maximum emission had been found and that the associated cable and EUT configuration and mode of operation had been identified.

4.6 Test Result

PASS.

The final test data is shown on as following pages.

Radiated Emission Measurement Data

EUT: Video Server CLIENT: VIVOTEK INC. MODEL: VS1601 RATING: 230V/50Hz Temperature: 19.0 °C Humidity: 73 %	POLARITY: Horizontal DISTANCE: 10 m Serial No.: FILE/DATA#: VIVOTEK INC.emi/4 OPERATOR: Nigel TEST SITE: OATS1
---	---

Frequency (MHz)	Factor (dB)	Meter Reading (dBμV)	Emission Level (dBμV/m)	Limits (dBμV/m)	Margin (dB)
114.541 **	-18.51	37.29	18.78	30.00	-11.22
215.981 **	-20.05	41.50	21.45	30.00	-8.55
323.983 **	-14.87	40.81	25.94	37.00	-11.06
374.995 **	-12.94	40.61	27.67	37.00	-9.33
456.186 **	-10.66	36.52	25.86	37.00	-11.14
489.126 **	-10.02	39.61	29.59	37.00	-7.41
552.957 **	-6.80	31.79	24.99	37.00	-12.01
663.527 **	-6.65	34.19	27.54	37.00	-9.46

Remark:

1. " * " Mark means readings are Peak Values.
2. " ** " Mark means readings are Quasi-Peak values.
3. Factor = Antenna Factor + Cable Loss – Pre-amplifier.

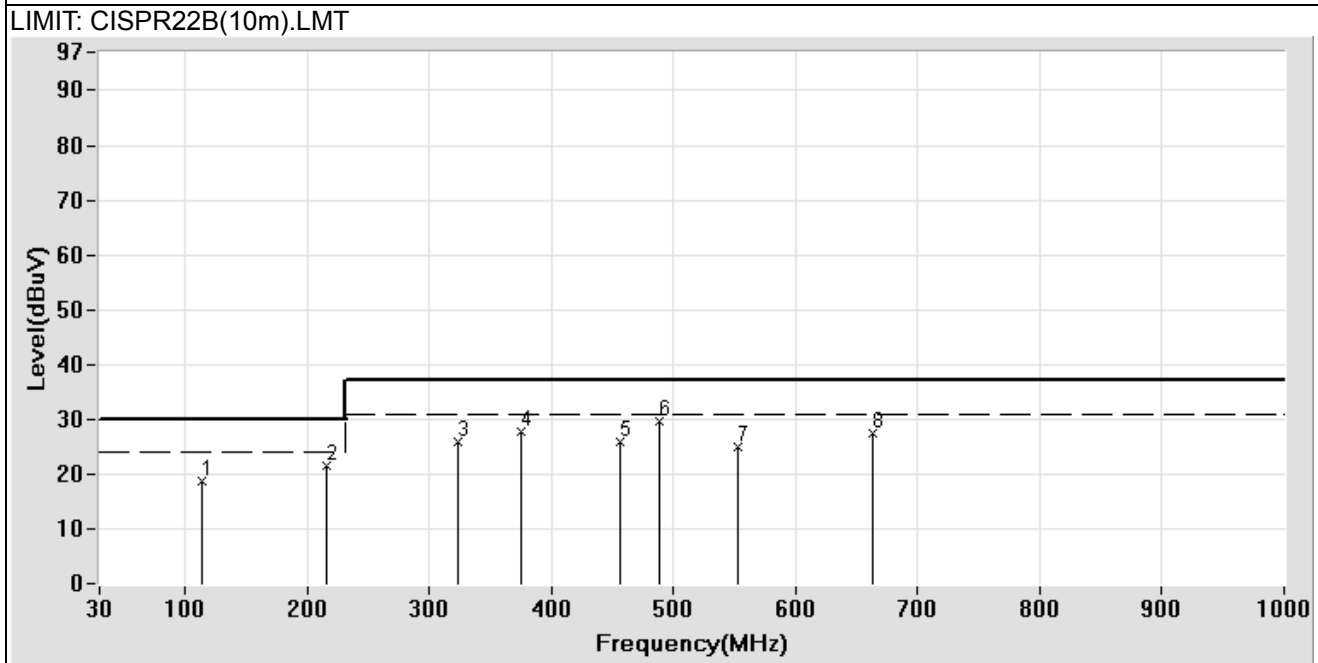

Test Mode: Mode 1: Working Mode

Radiated Emission Measurement Data

EUT: Video Server CLIENT: VIVOTEK INC. MODEL: VS1601 RATING: 230V/50Hz Temperature: 19.0 °C Humidity: 73 %	POLARITY: Vertical DISTANCE: 10 m Serial No.: FILE/DATA#: VIVOTEK INC.emi/5 OPERATOR: Nigel TEST SITE: OATS1
---	---

Frequency	Factor	Meter Reading	Emission Level	Limits	Margin
(MHz)	(dB)	(dBμV)	(dBμV/m)	(dBμV/m)	(dB)
55.270 **	-21.70	40.30	18.60	30.00	-11.40
115.298 **	-17.66	41.15	23.49	30.00	-6.51
199.993 **	-20.70	40.90	20.20	30.00	-9.80
215.981 **	-20.02	41.57	21.55	30.00	-8.45
323.002 **	-14.70	41.35	26.65	37.00	-10.35
345.979 **	-13.83	42.05	28.22	37.00	-8.78
374.991 **	-12.76	42.67	29.91	37.00	-7.09

Remark:

1. " * " Mark means readings are Peak Values.
2. " ** " Mark means readings are Quasi-Peak values.
3. Factor = Antenna Factor + Cable Loss – Pre-amplifier.

LIMIT: CISPR22B(10m).LMT

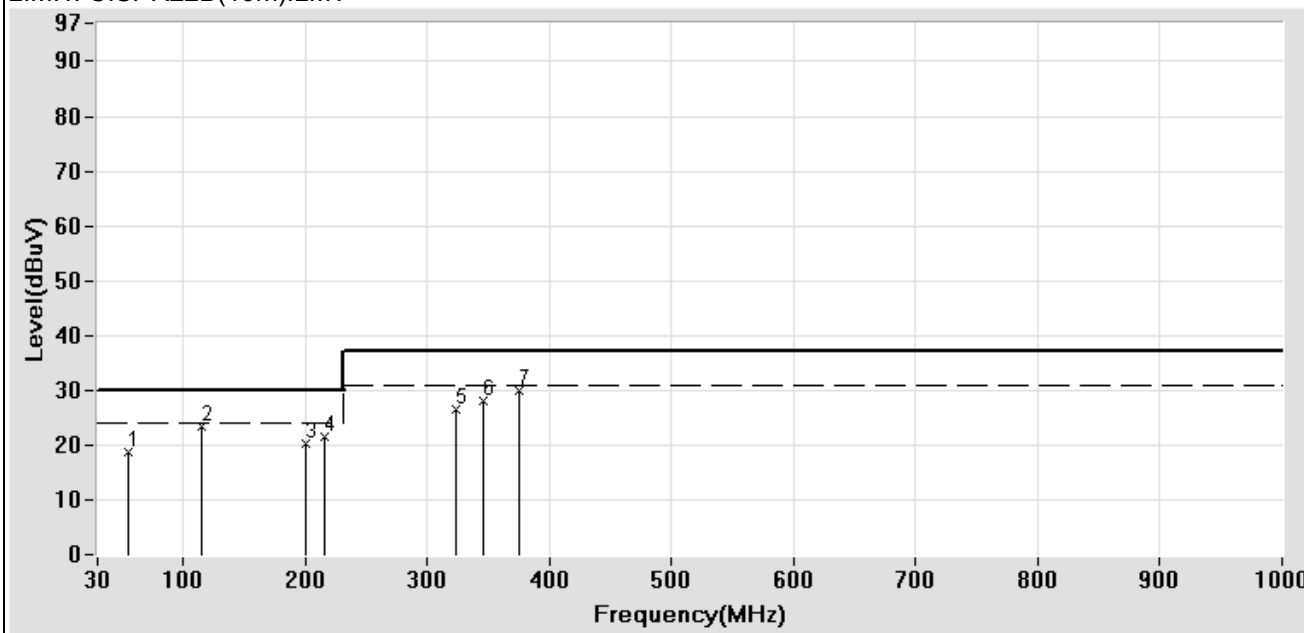

Test Mode: Mode 1: Working Mode

5 Harmonic Current Emission Measurement (EN 61000-3-2)

5.1 Instrument

Instrument	Manufacturer	Model	Serial No.	Last Calibration
Programmable AC Source	Chroma	6530	3447	2006/12/14
Universal Power Analyzer	VOLTECH	PM3000A	AL50/4717	2006/05/16
Reference Impedance Network	VOLTECH	IEC STANDADARD 555	IB521/4862	2006/09/01

Note: All instrument upon which need to be calibrated are within calibration period of 1 year.

5.2 Block Diagram of Test Configuration

Configuration of Instrument Setup.

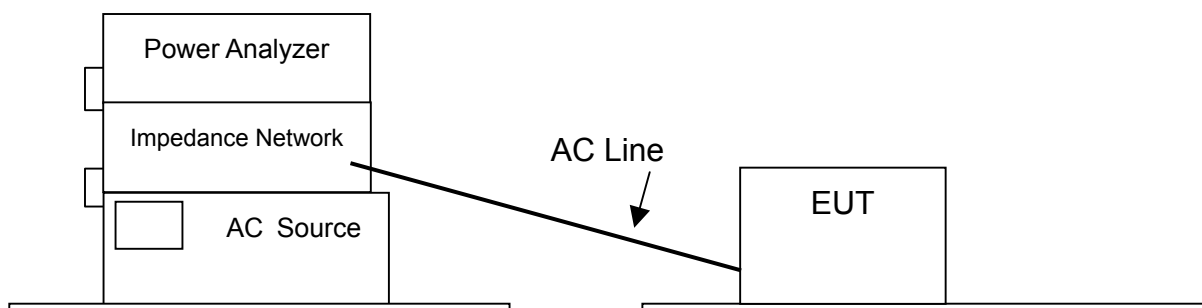

5.3 Test Limit

Class A Equipment

Harmonic order (n)	Maximum permissible harmonic current (A)
Odd harmonics	
3	2.30
5	1.14
7	0.77
9	0.40
11	0.33
13	0.21
$15 \leq n \leq 30$	$0.15 * 15 / n$
Even harmonics	
2	1.08
4	0.43
6	0.30
$8 \leq n \leq 40$	$0.23 * 8 / n$

Class D Equipment

Harmonic order (n)	Maximum permissible harmonic current per watt (mA/W)	Maximum permissible harmonic current
3	3.4	2.30
5	1.9	1.14
7	1.0	0.77
9	0.5	0.40
11	0.35	0.33
$13 \leq n \leq 39$ (odd harmonics only)	$3.85 / n$	See table 1

5.4 Configuration of Measurement

- 5.4.1 The EUT with power analyzer was in series and supplied from a power source with the same nominal voltage and frequency as the rated supply voltage.
- 5.4.2 Set the output of the power analyzer to the rated voltage and frequency of EUT (230V, 50Hz).
- 5.4.3 The EUT was classified by clause 5. of EN61000-3-2.

5.5 Test Result

PASS.

1. This rated power of EUT is under 75W therefore it isn't specified in this standard.
2. According to customer required, the measurement was performed with Class A limit. The measured result is shown on as following pages.

Product:	VIDEO SERVER	2007 Mar 27 9:51am Page 1 of 1
Serial no:	VS7100	
Description:	T:23.5°C H:49%	
Result Name:	PASS	
Voltech IEC1000-3 Windows Software 3.13.08		Test Date: 2007 Mar 27 9:46am
Type of Test:	Fluctuating Harmonics Test - Worst Case Table (2001)	
Power Analyzer:	Voltech PM3000A v2.19 s/n 4717	
AC Source:	Mains / Manual Source	
Overall Result:	PASS	

Class	Class A
Class Multiplier	1

Ham	Limit 1	Limit 2	Average Reading	<L1 <L2	Max Reading	<L2	Pass FAIL	Ham	Limit 1	Limit 2	Average Reading	<L1 <L2	Max Reading	<L2	Pass FAIL
2	1.0800A	1.6200A	0.126mA	✓ ✓	0.144mA	✓	N/A	3	2.3000A	3.4500A	22.82mA	✓ ✓	22.85mA	✓	Pass
4	430.0mA	645.0mA	0.107mA	✓ ✓	0.124mA	✓	N/A	5	1.1400A	1.7100A	22.35mA	✓ ✓	22.39mA	✓	Pass
6	300.0mA	450.0mA	0.123mA	✓ ✓	0.139mA	✓	N/A	7	770.0mA	1.1550A	21.51mA	✓ ✓	21.55mA	✓	Pass
8	230.0mA	345.0mA	0.126mA	✓ ✓	0.144mA	✓	N/A	9	400.0mA	600.0mA	20.35mA	✓ ✓	20.37mA	✓	Pass
10	184.0mA	276.0mA	0.112mA	✓ ✓	0.128mA	✓	N/A	11	330.0mA	495.0mA	19.03mA	✓ ✓	19.05mA	✓	Pass
12	153.3mA	230.0mA	0.132mA	✓ ✓	0.153mA	✓	N/A	13	210.0mA	315.0mA	17.51mA	✓ ✓	17.53mA	✓	Pass
14	131.4mA	197.1mA	0.096mA	✓ ✓	0.114mA	✓	N/A	15	150.0mA	225.0mA	16.00mA	✓ ✓	16.02mA	✓	Pass
16	115.0mA	172.5mA	0.142mA	✓ ✓	0.159mA	✓	N/A	17	132.3mA	198.5mA	14.39mA	✓ ✓	14.42mA	✓	Pass
18	102.2mA	153.3mA	0.085mA	✓ ✓	0.103mA	✓	N/A	19	118.4mA	177.6mA	12.83mA	✓ ✓	12.85mA	✓	Pass
20	92.00mA	138.0mA	0.109mA	✓ ✓	0.127mA	✓	N/A	21	107.1mA	160.7mA	11.18mA	✓ ✓	11.19mA	✓	Pass
22	83.63mA	125.4mA	0.085mA	✓ ✓	0.101mA	✓	N/A	23	97.82mA	146.7mA	9.572mA	✓ ✓	9.582mA	✓	Pass
24	76.66mA	115.0mA	0.084mA	✓ ✓	0.100mA	✓	N/A	25	90.00mA	135.0mA	7.972mA	✓ ✓	7.980mA	✓	Pass
26	70.76mA	106.1mA	0.079mA	✓ ✓	0.094mA	✓	N/A	27	83.33mA	125.0mA	6.429mA	✓ ✓	6.437mA	✓	Pass
28	65.71mA	98.57mA	0.046mA	✓ ✓	0.058mA	✓	N/A	29	77.58mA	116.3mA	5.049mA	✓ ✓	5.056mA	✓	Pass
30	61.33mA	92.00mA	0.068mA	✓ ✓	0.080mA	✓	N/A	31	72.58mA	108.8mA	3.759mA	✓ ✓	3.766mA	✓	N/A
32	57.50mA	86.25mA	0.034mA	✓ ✓	0.045mA	✓	N/A	33	68.18mA	102.2mA	2.725mA	✓ ✓	2.731mA	✓	N/A
34	54.11mA	81.17mA	0.054mA	✓ ✓	0.062mA	✓	N/A	35	64.28mA	96.42mA	1.794mA	✓ ✓	1.799mA	✓	N/A
36	51.11mA	76.66mA	0.036mA	✓ ✓	0.041mA	✓	N/A	37	60.81mA	91.21mA	1.154mA	✓ ✓	1.158mA	✓	N/A
38	48.42mA	72.63mA	0.031mA	✓ ✓	0.037mA	✓	N/A	39	57.69mA	86.53mA	0.670mA	✓ ✓	0.676mA	✓	N/A
40	46.00mA	69.00mA	0.052mA	✓ ✓	0.056mA	✓	N/A								

<L1 : Reading is below limit 1.

<L2 : Reading is below limit 2.

N/A : Harmonic current below 0.6% of rated current or 5mA, whichever is greater, are disregarded.

Product:	VIDEO SERVER	2007 Mar 27 9:49am Page 1 of 1
Serial no:	VS7100	
Description:	T:23.5°C H:49%	
Result Name:	PASS	
Voltech IEC1000-3 Windows Software 3.13.08		Test Date: 2007 Mar 27 9:46am
Type of Test:	Fluctuating Harmonics Test - Linear Bar Chart (2001)	
Power Analyzer:	Voltech PM3000A v2.19 s/n 4717	
AC Source:	Mains / Manual Source	
Overall Result:	PASS	

Class	A
Class Multiplier	1
Power	5.4 W

Reading 1

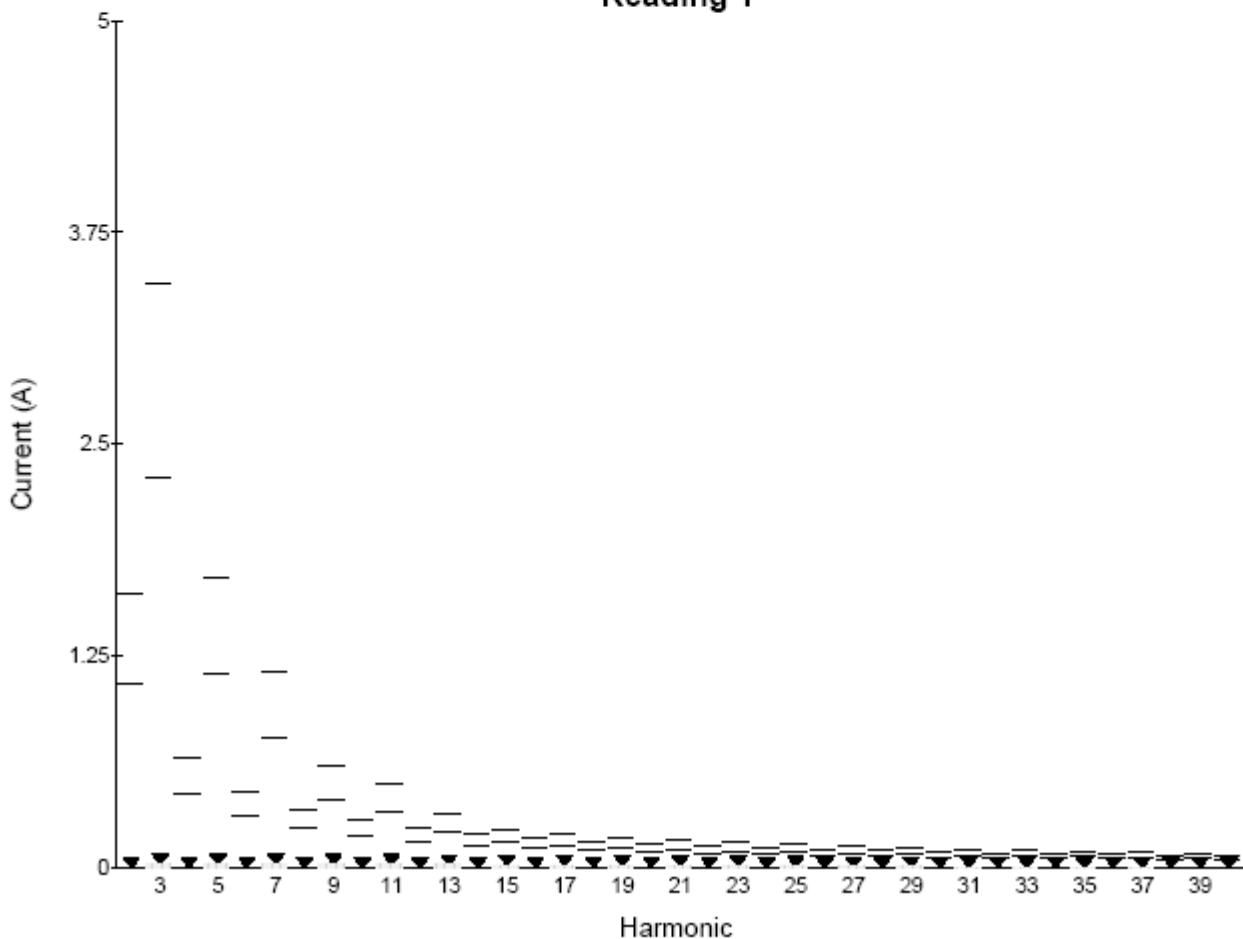

Product: VIDEO SERVER Serial no: VS7100 Description: T:23.5°C H:49% Test Date: 2007 Mar 27 9:46am Result Name: PASS		2007 Mar 27 9:50am Page 1 of 1	
Type of Test: EN61000:2001 Harmonics Limits: Class A Power Analyzer: Voltech PM3000A v2.19 s/n 4717 AC Source: Mains / Manual Source			
Harmonic Results Against Chosen Limits: <div style="font-size: 2em; color: green; text-align: center;">PASS</div>		Notes:	
Test Parameter Details		User Entered	Measured
Operating Frequency:	50	49.9922	
Operating Voltage:	230	228.8245	
Specified Power:	5.4100	5.3857	
Fundamental Current:	0.0000	0.0294	
Power Factor:	0.0000	0.3499	
Average Input Current:		0.0666	
Maximum POHC:		0.0193	
POHC Limit:		0.2514	
Maximum THC:		0.0598	
Minimum Power:	75		
Class Multiplier:	1.0000		
Test Duration:	00:02:30		

6 Voltage Fluctuations and Flicker Measurement (EN 61000-3-3)

6.1 Instrument

Instrument	Manufacturer	Model	Serial No.	Last Calibration
Programmable AC Source	Chroma	6530	3447	2006/12/14
Universal Power Analyzer	VOLTECH	PM3000A	AL50/4717	2006/05/16
Reference Impedance Network	VOLTECH	IEC STANDADARD 555	IB521/4862	2006/09/01

Note: All instrument upon which need to be calibrated are within calibration period of 1 year.

6.2 Block Diagram of Test Configuration

Configuration of Instrument Setup.

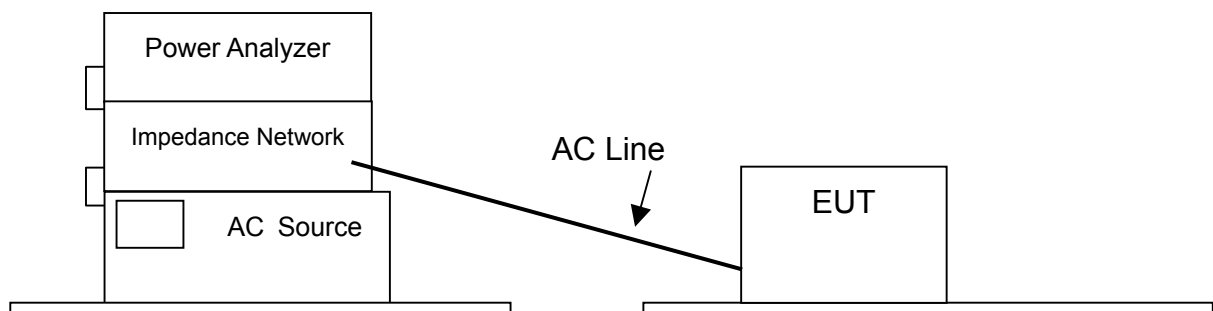

6.3 Test Limit

The following limits apply:

- the value of P_{st} shall not be greater than 1.0;
- the value of P_{lt} shall not be greater than 0.65;
- the relative steady-state voltage change, d_c , shall not exceed 3.3%;
- the maximum relative voltage change, d_{max} , shall not exceed 4%;
- the value of $d(t)$ during a voltage change shall not exceed 3.3% for more than 500 ms.

6.4 Configuration of Measurement

- 6.4.1 The EUT with power analyzer is in series and supplied from a power source with the same nominal voltage and frequency as the rated supply voltage.
- 6.4.2 Set the output of the power analyzer to the rated voltage and frequency of EUT (230V, 50Hz).
- 6.4.3 Select the test time of observation period for short-term ($T_p = 10$ min) and long-term ($T_p = 2$ hrs). The test result was collected and analyzed by the computer.

6.5 Test Result

PASS.

The measured result is shown on as following pages.

Product:	VIDEO SERVER			2007 Mar 27 9:44am
Serial no:	VS7100			Page 1 of 1
Description:	T:23.5°C H:49%			
Result Name:	PASS			
Voltech IEC1000-3 Windows Software 3.13.08			Test Date: 2007 Mar 27 9:32am	
Type of Test:	Flickermeter Test - Table			
Power Analyzer:	Voltech PM3000A v2.19 s/n 4717			
AC Source:	Mains / Manual Source			
Overall Result:	Notes:			
PASS	Measurement method - Voltage			
	Pst	dc (%)	dmax (%)	d(t) > 3.3%(ms)
Limit	1.000	3.300	4.000	500
Reading 1	0.071	0.017	0.038	0

7 Electrostatic Discharge Immunity Test (IEC 61000-4-2)

7.1 Instrument

Instrument	Manufacturer	Model	Serial No.	Last Calibration
ESD Simulator	EMC PARTNER	ESD3000	241	2006/10/09

Note: All instrument upon which need to be calibrated are within calibration period of 1 year.

7.2 Block Diagram of Test Configuration

Configuration of Instrument Setup.

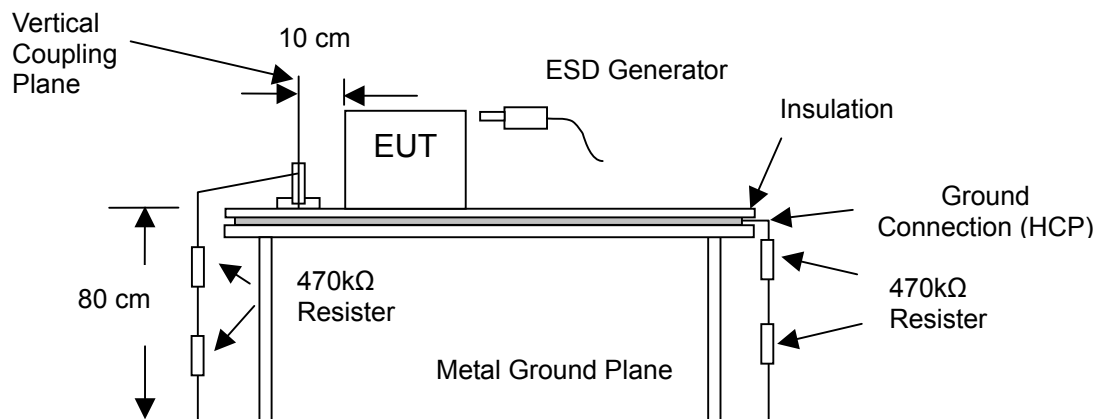

7.3 Test Levels & Performance Criterion

7.3.1 Test Levels

Level	Contact discharge (kV)	Air discharge (kV)
1	2	2
2	4	4
3	6	8
4	8	15
X	Special	Special

7.3.2 Performance Criterion

Criterion	Description
A	The equipment shall continue to operate as intended without operator intervention, degradation of performance or loss of function is allowed below a performance level specified by the manufacturer when the equipment is used as intended.
B	After the test, the equipment shall continue to operate as intended without operator intervention, degradation of performance or loss of function is allowed.
C	Loss of function is allowed, provided the function is self-recoverable, or can be restored by the operation of controls by the user in accordance with the manufacturer's instructions.

7.4 Test Requirement

- 7.4.1 Air discharge: ± 8 kV
- 7.4.2 Contact discharge: ± 4 kV
- 7.4.3 Indirect discharge: ± 4 kV
- 7.4.4 Performance criterion: B

7.5 Configuration of Measurement

- 7.5.1 Static electricity discharges shall be applied only to those points and surfaces of the EUT which are expected to be touched during usual operation, including user access, as specified in the user manual, for example for ribbon and paper roll changes.
- 7.5.2 The discharges shall be applied in two ways:
 - a) Contact discharges to the conductive surfaces and to coupling planes:

The EUT shall be exposed to at least 200 discharges, 100 each at negative and positive polarity, at a minimum of four test points (a minimum of 50 discharges at each point). One of the test points shall be subjected to at least 50 indirect discharges (contact) to the center of the front edge of the horizontal coupling plane, The remaining three test points shall each receive at least 50 direct contact discharges. If no direct contact test points are available, then at least 200 indirect discharges shall be applied in the indirect mode (see IEC 61000-4-2 for use of the Vertical Conducting Plane (VCP)). Tests shall be performed at a maximum repetition rate of one discharge per second.
 - b) Air discharge at slots and apertures, and insulating surfaces:

On those parts of the EUT where it is not possible to perform contact discharge testing, the equipment should be investigated to identify user accessible points where breakdown may occur; examples are openings at edges of keys, or in the covers of keyboards and telephone handsets. Such points are tested using the air discharge method. See also IEC 61000-4-2 regarding painted surfaces. This investigation should be restricted to those areas normally handled by the user. A minimum of 10 single air discharges shall be applied to the selected test point for each such area.
- 7.5.3 The selected points, performed with electrostatic discharge were marked with red labels on the EUT. The ESD generator (gun) was held perpendicular to the surface to which the discharge was applied. The application of electrostatic discharges to the contacts of open connectors is not required.

7.6 Test Result

The performance criterion after tested is:

Air discharge:	<input checked="" type="checkbox"/> A	<input type="checkbox"/> B	<input type="checkbox"/> C
Contact discharge:	<input checked="" type="checkbox"/> A	<input type="checkbox"/> B	<input type="checkbox"/> C
Indirect discharge:	<input checked="" type="checkbox"/> A	<input type="checkbox"/> B	<input type="checkbox"/> C

8 Radio-frequency, Electromagnetic field Immunity Test (IEC 61000-4-3)

8.1 Instrument

Instrument	Manufacturer	Model	Serial No.	Last Calibration
Signal Generator	R&S	SMY02	829846/013	2006/07/20
Power Amplifier	KALMUS	7100LC	8948-1	2006/06/19
Field Probe	HOLADAY INDUSTRIES	HI-4422	101635	2006/04/19
Coupler	WERLATONE	C2630	8067	N. C. R.
Bilog Antenna	SCHWARZBECK	VULB9161	4023	2006/09/13
Power Meter	Agilent	E4419B	GB40201802	2006/06/19

Note: All instrument upon which need to be calibrated are within calibration period of 1 year.

8.2 Block Diagram of Test Configuration

Configuration of Instrument Setup.

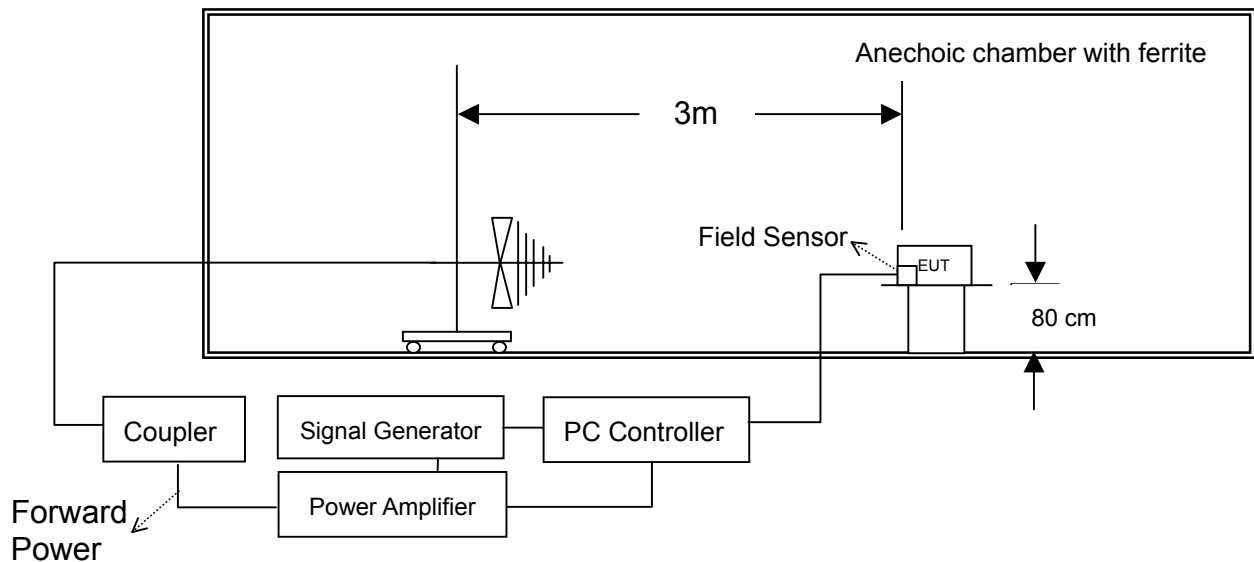

8.3 Test Levels & Performance Criterion

8.3.1 Test Levels

Level	Test field strength (V/m)
1	1
2	3
3	10
X	Special

8.3.2 Performance Criterion

Criterion	Description
A	The equipment shall continue to operate as intended without operator intervention, degradation of performance or loss of function is allowed below a performance level specified by the manufacturer when the equipment is used as intended.
B	After the test, the equipment shall continue to operate as intended without operator intervention, degradation of performance or loss of function is allowed.
C	Loss of function is allowed, provided the function is self-recoverable, or can be restored by the operation of controls by the user in accordance with the manufacturer’s instructions.

8.4 Test Requirement

8.4.1 Frequency range: 80 to 1000 MHz, Field strength: 3 V/m, 80%AM (1kHz),
Performance criterion: A

8.5 Configuration of Measurement

- 8.5.1 Before testing, the intensity of the established field strength was checked by placing the field sensor at a calibration grid point, and with the field generating antenna and cables in the same positions as used for the calibration, the forward and reverse power were measured. The forward power needed to give the calibrated field was evaluated.
- 8.5.2 After the calibration had been verified, the test field was then generated using the values obtained from the calibration. The EUT and the auxiliary equipment were placed on a table with 0.8 meters height. The EUT was initially placed with one face coincidence with the calibration plane at a distance of 3 meters away from the illuminating antenna (the same as used for the field calibration). Both horizontal and vertical polarizations of the antenna and four sides of the EUT were set for the radiated field immunity test.
- 8.5.3 In order to survey the performance of the EUT, a CCD camera was used to monitor the EUT performance.

8.6 Test Result

The performance criterion after tested is as following:

Frequency range: **80** to **1000** MHz, Field strength: **3** V/m, 80% AM (1kHz),
Performance criterion: **A** **B** **C**

9 Electrical Fast Transient/Burst Immunity Test (IEC 61000-4-4)

9.1 Instrument

Instrument	Manufacturer	Model	Serial No.	Last Calibration
EMC Pro System	KeyTek	EMC Pro	0003231	2007/03/16
EFT Clamp	KeyTek	PRO-CCL-C	0003198	N. C. R.

Note: All instrument upon which need to be calibrated are within calibration period of 1 year.

9.2 Block Diagram of Test Configuration

Configuration of Instrument Setup.

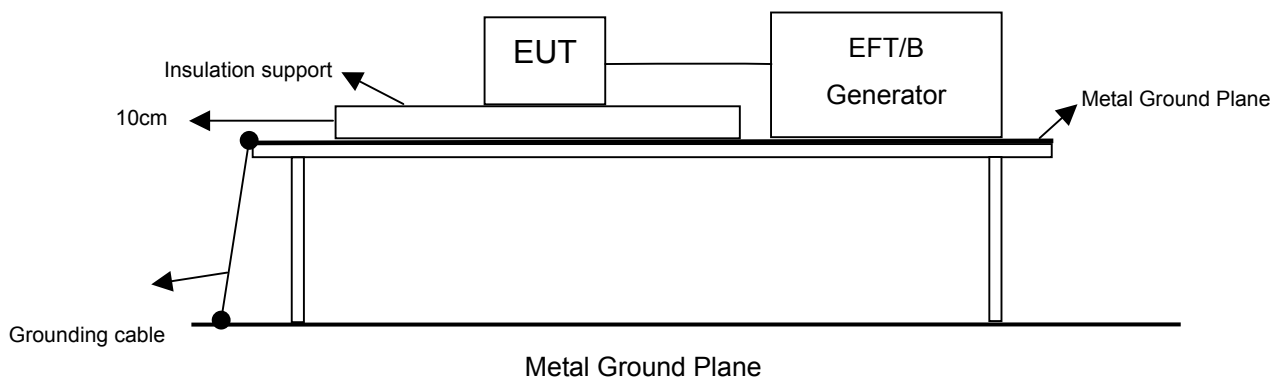

9.3 Test Levels & Performance Criterion

9.3.1 Test Levels

Level	On power supply port, PE		On I/O signal, data and control ports	
	Voltage Peak (kV)	Repetition rate (kHz)	Voltage Peak (kV)	Repetition rate (kHz)
1	0.5	5	0.25	5
2	1	5	0.5	5
3	2	5	1	5
4	4	2.5	2	5
X	Special	Special	Special	Special

9.3.2 Performance Criterion

Criterion	Description
A	The equipment shall continue to operate as intended without operator intervention, degradation of performance or loss of function is allowed below a performance level specified by the manufacturer when the equipment is used as intended.
B	After the test, the equipment shall continue to operate as intended without operator intervention, degradation of performance or loss of function is allowed.
C	Loss of function is allowed, provided the function is self-recoverable, or can be restored by the operation of controls by the user in accordance with the manufacturer's instructions.

9.4 Test Requirement

- 9.4.1 5 kHz Repetition frequency
- 9.4.2 Performance criterion: B
- 9.4.3 ±1.0 kV input ac power ports.
 ±0.5 kV for Signal, telecommunication,
 ±0.5 kV input d.c power ports.

9.5 Configuration of Measurement

- 9.5.1 The EUT and the auxiliary equipment were placed on a wooden table of 0.8 meters height. The size of ground plane is greater than 1m×1m and project beyond the EUT by at least 0.1m on all sides. The ground plane is connected to the protective earth.
- 9.5.2 The EUT was connected to the power mains through a coupling device that directly couples the EFT interference signal. Each of the Line, Neutral and Protective Earth (PE) conductors was impressed with burst noise for 1 minute. Both the voltage polarities were applied for each test level. The length of power cord between the coupling device and the EUT was less than 1 meter.

9.6 Test Result

The performance criterion after tested is:

- ±1.0 kV input ac power ports,
Performance criterion: **A** **B** **C**
- ±0.5 kV for Signal, telecommunication,
Performance criterion: **A** **B** **C**

10 Surge Immunity Test (IEC 61000-4-5)

10.1 Instrument

Instrument	Manufacturer	Model	Serial No.	Last Calibration
EMC Pro Systems	KeyTek	EMC Pro	0003234	2007/03/22
Surge Telecom Box	KeyTek	CM-TELCD	0202316	N. C. R.

Note: All instrument upon which need to be calibrated are within calibration period of 1 year.

10.2 Block Diagram of Test Configuration

Configuration of Instrument Setup.

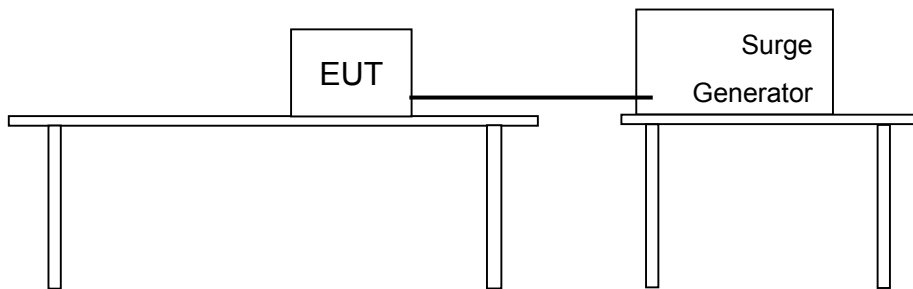

10.3 Test Levels & Performance Criterion

10.3.1 Test Levels

Level	Open-circuit test voltage (kV) Line to earth	Open-circuit test voltage (kV) Line to line
1	0.5	--
2	1.0	0.5
3	2.0	1.0
4	4.0	--
X	Special	--

NOTE: x is an open class. This level can be specified in the product specification.

10.3.2 Performance Criterion

Criterion	Description
A	The equipment shall continue to operate as intended without operator intervention, degradation of performance or loss of function is allowed below a performance level specified by the manufacturer when the equipment is used as intended.
B	After the test, the equipment shall continue to operate as intended without operator intervention, degradation of performance or loss of function is allowed.
C	Loss of function is allowed, provided the function is self-recoverable, or can be restored by the operation of controls by the user in accordance with the manufacturer's instructions.

10.4 Test Requirement

- 10.4.1 Input ac power ports: Line to line: ±1kV (peak), 1.2/50 (8/20) Tr/Th us
 Line to earth (ground): ±2kV (peak), 1.2/50 (8/20) Tr/Th us
- 10.4.2 Input dc power ports: ±0.5kV(peak): line to earth, 1.2/50 (8/20) Tr/Th us
 Signal and telecommunication ports: ±1.0kV(peak): 1.2/50 (8/20) Tr/Th us
- 10.4.3 Performance criterion: **B**

10.5 Configuration of Measurement

- 10.5.1 The EUT and the auxiliary equipment were placed on a table of 0.8m heights above a metal ground reference plane. The size of ground plane is greater than 1m×1m and project beyond the EUT by at least 0.1m on all sides. The ground plane is connected to the protective earth. The length of power cord between the coupling device and the EUT was less than 2 meters (provided by the manufacturer).
- 10.5.2 The EUT was connected to the power mains through a coupling device that directly couples the Surge interference signal. The surge noise was applied synchronized to the voltage phase at the zero crossing and the peak value of the AC voltage wave (positive and negative).
- 10.5.3 The surges were applied line to line and line(s) to earth. When testing line to earth the test voltage was applied successively between each of the lines and earth. Steps up to the test level specified increased the test voltage. All lower levels including the selected test level were tested. The polarity of each surge level included positive and negative test pulses.

10.6 Test Result

The performance criterion after tested as following:

- ±0.5 kV (peak): Line to line
Performance criterion: **A** **B** **C**
- ±1.0 kV (peak): Line to line
Performance criterion: **A** **B** **C**

11 Radio-frequency, Conducted Disturbances Immunity Test (IEC 61000-4-6)

11.1 Instrument

Instrument	Manufacturer	Model	Serial No.	Last Calibration
CS TEST SYSTEM	FRANKONIA	CIT-10	102D1278	2006/11/22
Coupler	WERLATONE	C2630	8067	N. C. R.
Attenuator	BIRD Electronic Corp.	25-A-MFN-06	00026	2006/05/19
M3 C.D.N	FCC	FCC-801-M3-25A	2045	2006/05/24
M2 C.D.N	SCHAFFNER	M216	16394	2006/05/24
Power Meter	Agilent	E4479B	GB40201802	2006/06/19
CS TEST SYSTEM	FRANKONIA	CIT-10	102D1278	2006/11/22

Note: All instrument upon which need to be calibrated are within calibration period of 1 year.

Instrument	Manufacturer	Model	Serial No.	Last Calibration
EM-CLAMP	SCHAFFNER	KEMZ 801	17037	2005/06/14

Note: All instrument upon which need to be calibrated are within calibration period of 2 years.

11.2 Block Diagram of Test Configuration

Configuration of Instrument Setup.

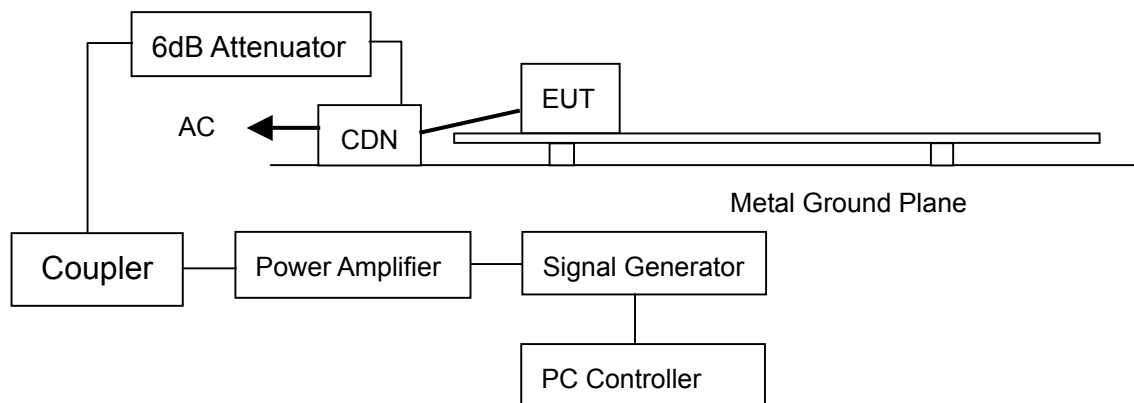

11.3 Test Levels

Level	Voltage Level (V)
1	1
2	3
3	10
X	Special

11.4 Test Requirement

- 11.4.1 Frequency Range is from 0.15 to 80MHz.
- 11.4.2 Field strength: 3 V, 80% AM (1kHz)
 - Input AC power port.
 - Signal and telecommunication ports.
 - Input DC power port.
- 11.4.3 Performance criterion: A

11.5 Configuration of Measurement

- 11.5.1 The EUT was placed on a table of is 0.1 m height. In Semi-Anechoic chamber A Ground reference plane was placed on the table and a 0.1 meter insulating support was inserted between the EUT and Ground reference plane.
- 11.5.2 The EUT was connected to the power mains through a Coupling and Decoupling Networks (CDN).
- 11.5.3 The test was performed with the test generator connected to each of the coupling and decoupling devices in turn while the other non-excited RF input ports of the coupling devices were terminated by a 50 Ω terminator.
- 11.5.4 The frequency range was swept from 150kHz to 80MHz.using the signal levels established during the setting process, and without the disturbance signal 80% amplitude modulated with a 1 kHz sine wave, pausing to adjust the RF signal level or to switch coupling devices as necessary. The rate of sweep was less than 1.5×10^{-3} decades/s. And the step size of the frequency sweep was also less than 1% of the start and thereafter 1% of the preceding frequency value. The dwell time at each frequency was more than the time necessary for the EUT to be excited, and able to respond.
- 11.5.5 The EUT was fully excised during the testing and all the selected excise modes were fully interrogated for susceptibility.

11.6 Test Result

The performance criterion after tested is:

Frequency range: **0.15** to **80** MHz, Field strength: **3** V, 80% AM (1kHz),

- Input AC power port.
 - Performance criterion: **A** **B** **C**
- Signal and telecommunication ports.
 - Performance criterion: **A** **B** **C**

12 Power frequency magnetic field immunity test (IEC 61000-4-8)

According to EN55024, Clause 4.2.4, Physically large products need not be completely submerged in the magnetic field, only the sensitive devices (such as CRT monitors if they are the only sensitive parts).

The EUT did not contain devices susceptible to magnetic fields; do not need to perform this test.

13 Voltage Dips, Short Interruptions Immunity Test (IEC 61000-4-11)

13.1 Instrument

Instrument	Manufacturer	Model	Serial No.	Last Calibration
EMC Pro System	KeyTek	EMC Pro	0003231	2007/03/22

Note: All instrument upon which need to be calibrated are within calibration period of 1 year.

13.2 Block Diagram of Test Configuration

Configuration of Instrument Setup.

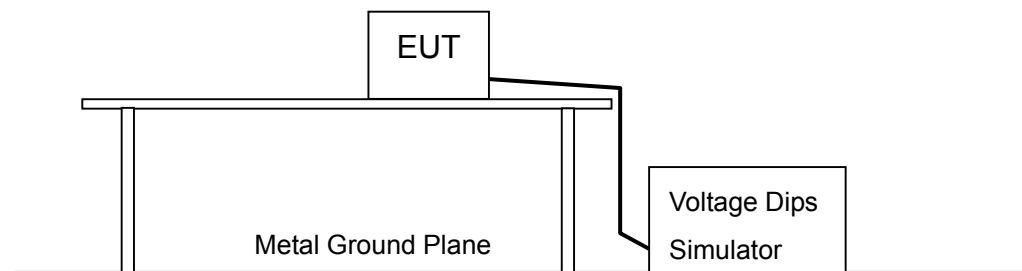

13.3 Test Levels

Level (% U _T)	Voltage dip & short interruptions (% U _T)
70	30
40	60
0	100

13.4 Test Requirement

- 13.4.1 > 95% Voltage Dips, 0.5 period, Performance criterion: B
- 13.4.2 30% reduction (Voltage Dips), 25 period, Performance criterion: C
- 13.4.3 > 95% Voltage Interruptions, 250 period, Performance criterion: C

13.5 Configuration of Measurement

- 13.5.1 The power cord was used as supplied by the manufacturer. The EUT was connected to the line output of the Voltage Dips and Interruption Generator.
- 13.5.2 The EUT was tested for (I) 95% voltage dip of supplied voltage with duration of 10ms, (II) 30% voltage dip of supplied voltage and duration 500ms. Both of the dip tests were carried out for a sequence of three voltage dips with intervals of 10 seconds.
- 13.5.3 A 95% voltage interruption of supplied voltage with duration of 5000ms was followed, which was a sequence of three voltage interruptions with intervals of 10 seconds.
- 13.5.4 Voltage reduction was controlled at 0°, 90° and 270° of the voltage phase angle. The performance of the EUT was checked after the voltage dip or interruption.

13.6 Test Result

The performance criterion after tested is:

- > 95% Voltage Dips, 0.5 period
Performance criterion: **A** **B** **C**
- 30% reduction (Voltage Dips), 25 period
Performance criterion: **A** **B** **C**
- > 95% Voltage Interruptions, 250 period
Performance criterion: **A** **B** **C**

Note: During 95% voltage interruptions test, the EUT was shut down for a while and restored automatically after the test.

14 Photographs of Test

14.1 Power Line Conducted Emission Measurement



Front View



Rear View

14.2 Radiated Emission Measurement



Front View



Rear View

14.3 Harmonic Current & Voltage Fluctuations and Flicker Measurement



14.4 Electrostatic Discharge Immunity Test (IEC 61000-4-2)



14.5 Radio-Frequency, Electromagnetic Field Immunity Test (IEC 61000-4-3)



Front View



Rear View

14.6 Electrical Fast Transient/Burst Immunity Test (IEC 61000-4-4)



14.7 Surge Immunity Test (IEC 61000-4-5)

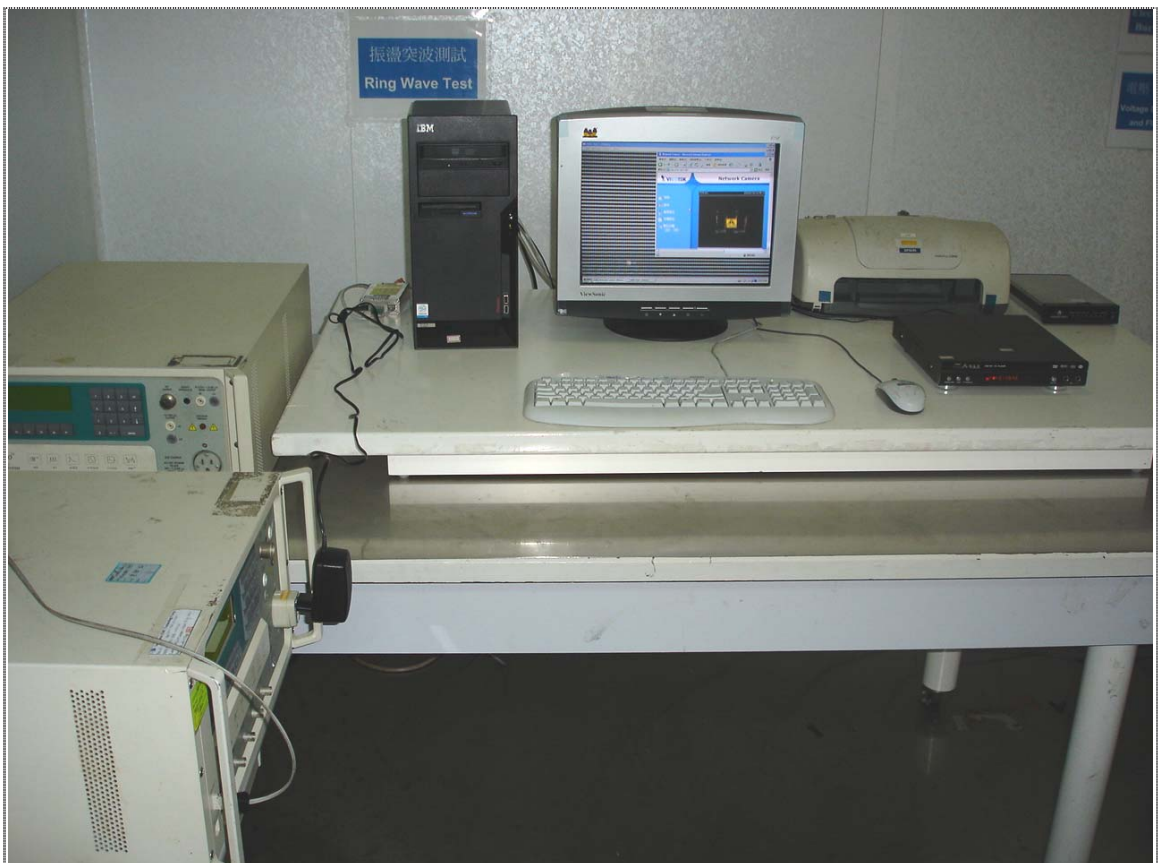

14.8 Radio-Frequency, Conducted Disturbances Immunity Test (IEC 61000-4-6)



14.9 Voltage Dips, Short Interruptions Immunity Test (IEC 61000-4-11)



14.10 Electrostatic Discharge Test Point

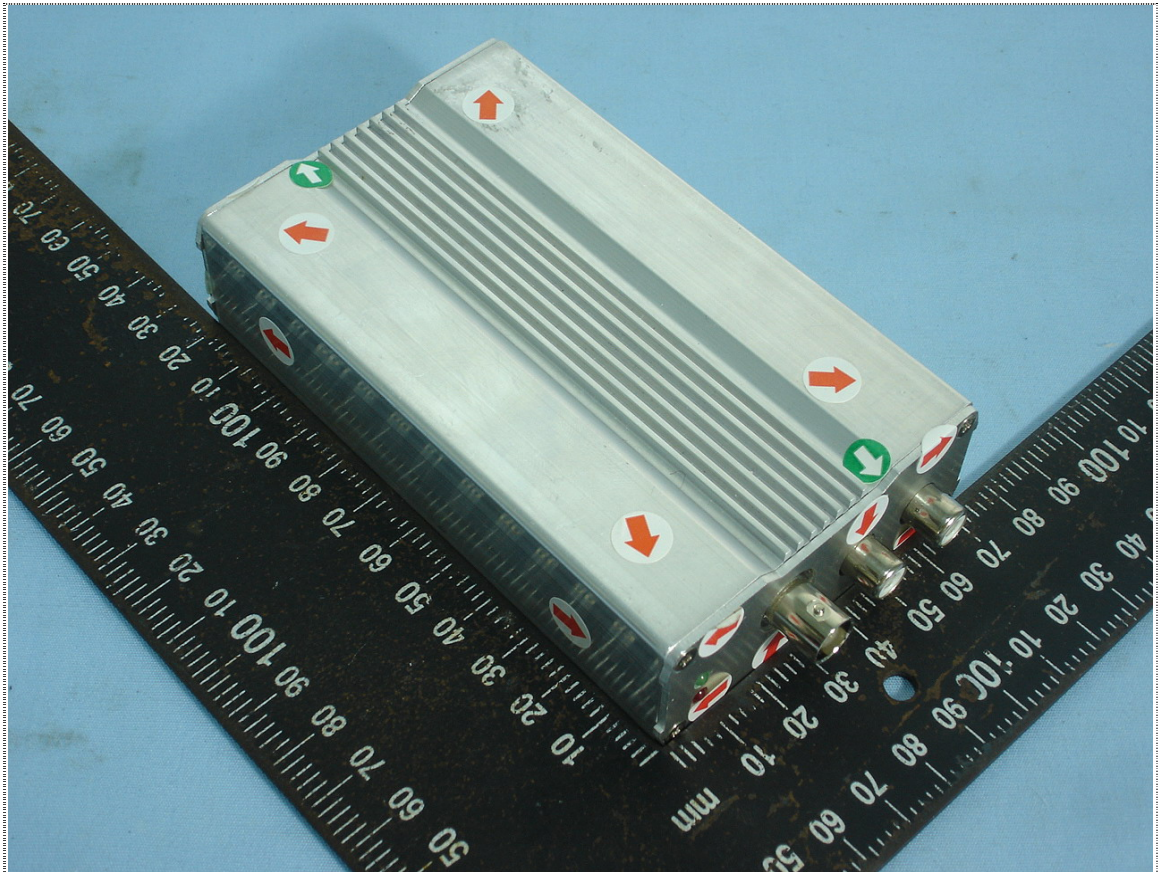

View of Discharge Point-1 (Green: Air discharge, Red: Contact discharge)



View of Discharge Point-2 (Green: Air discharge, Red: Contact discharge)

15 Photographs of EUT

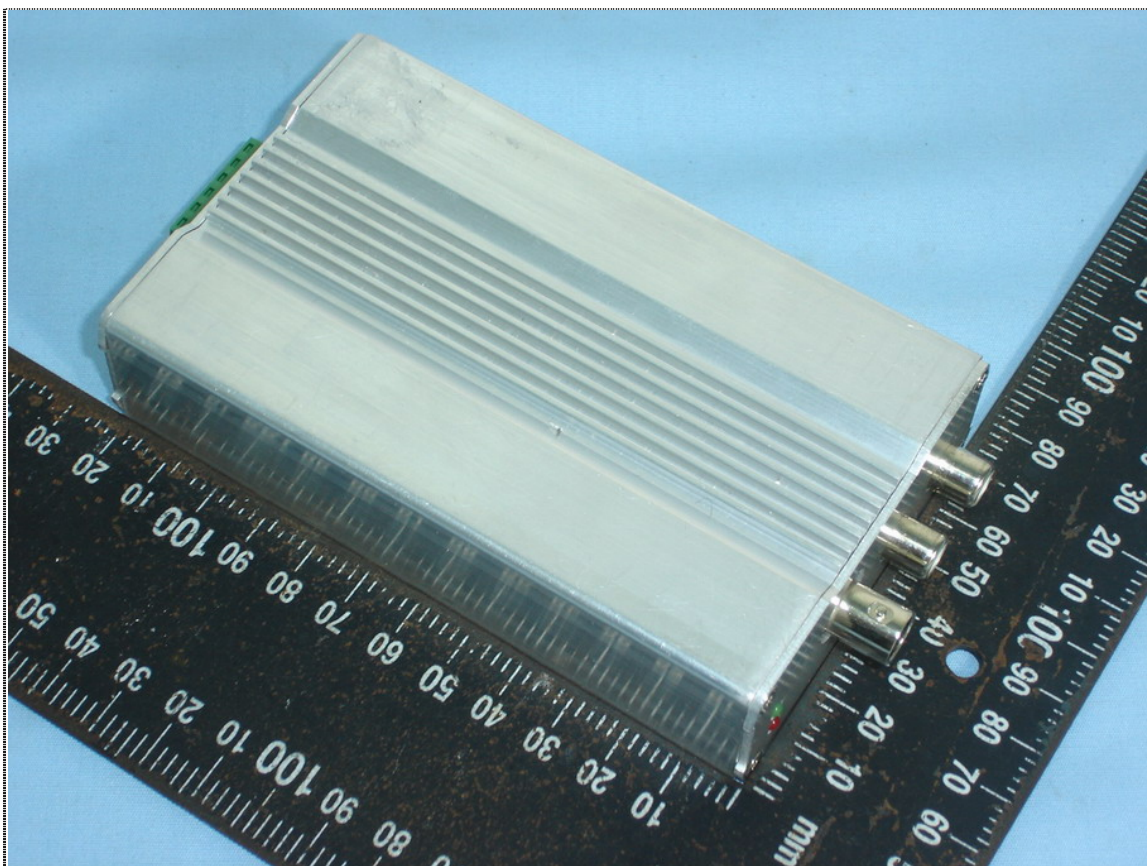

Front View of EUT

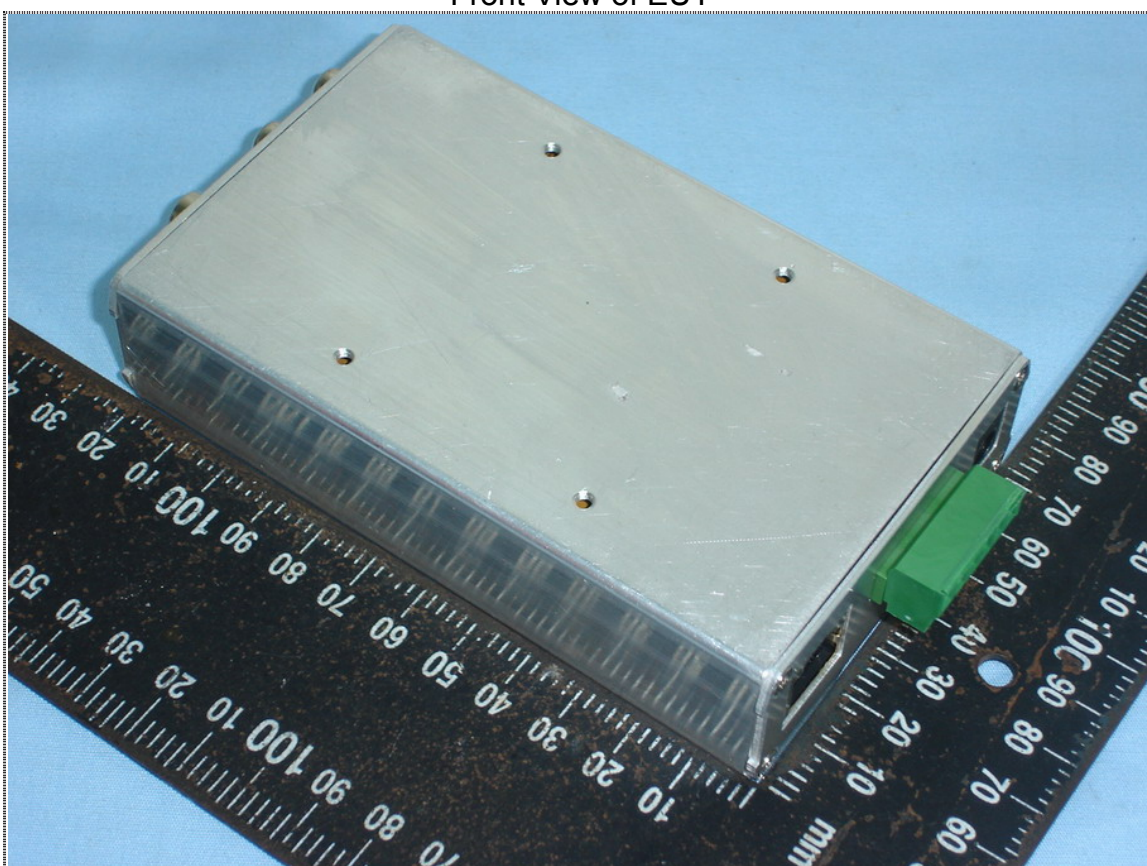

Rear View of EUT

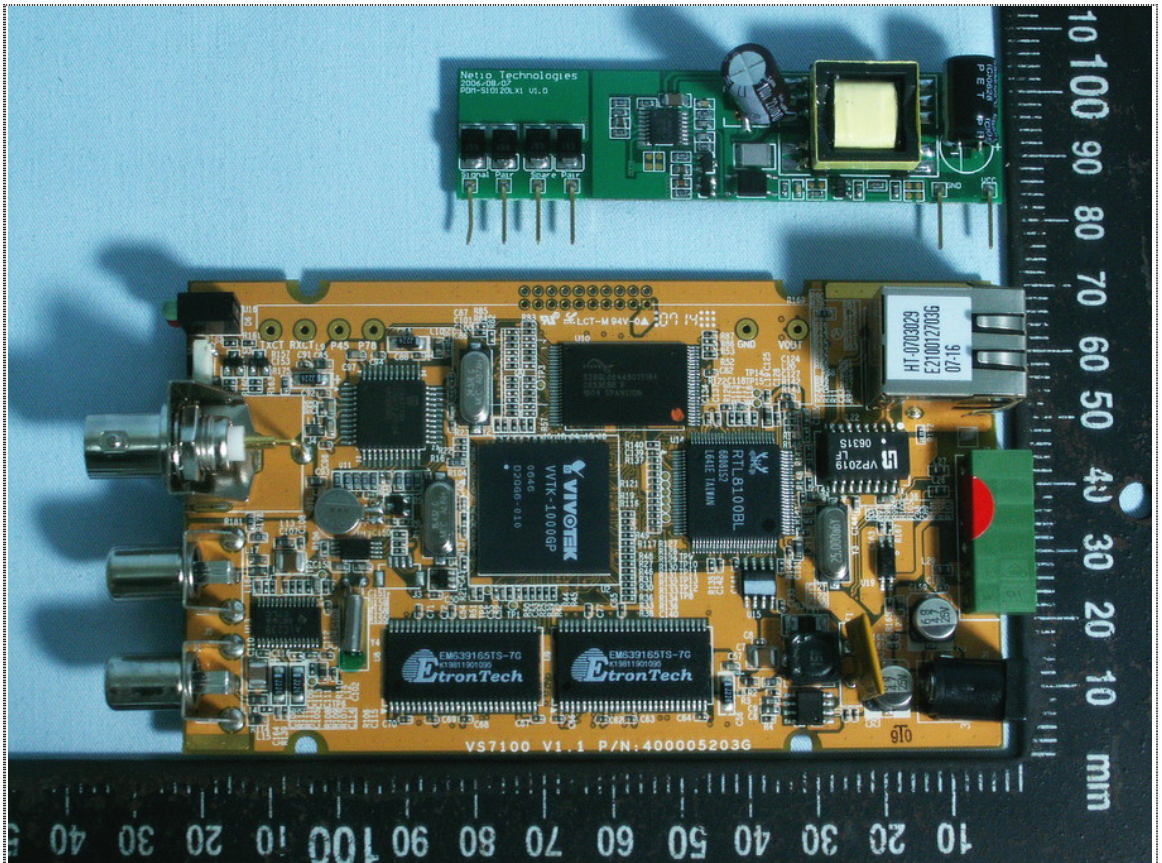

Front view of Main Board-1

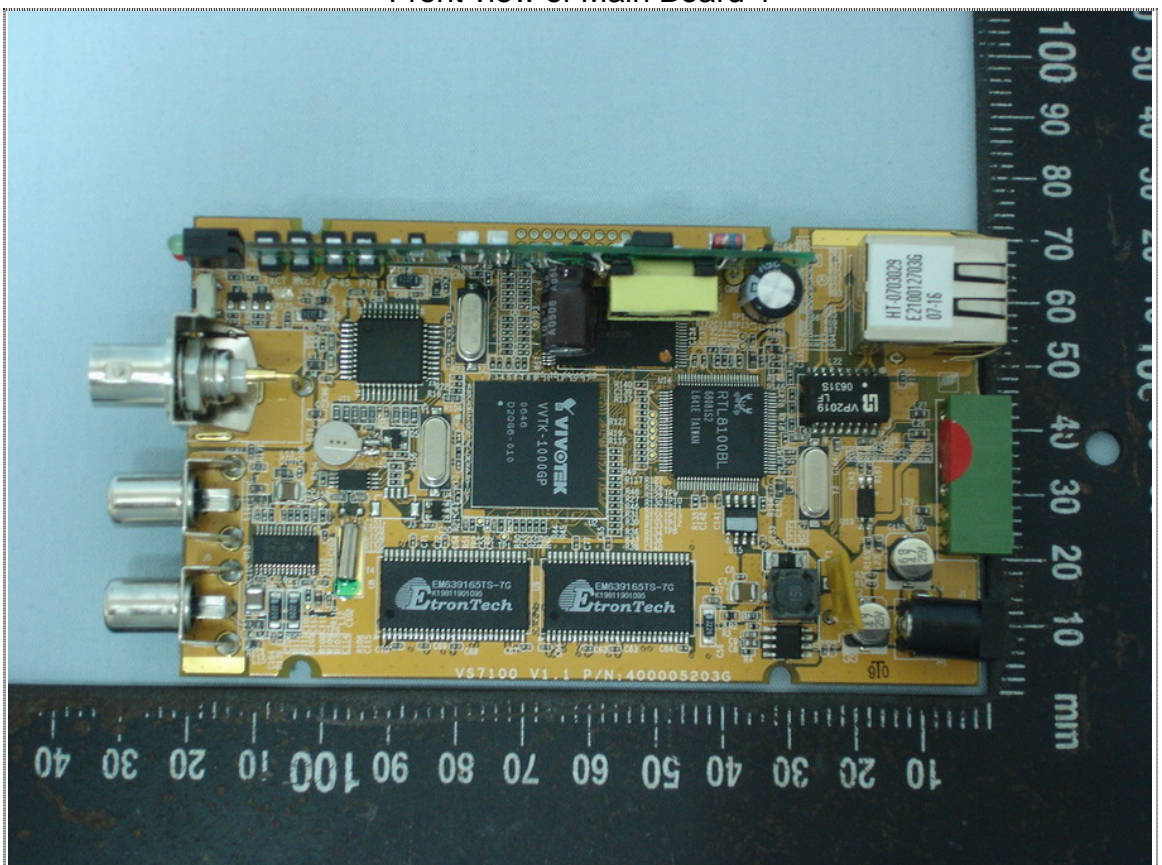

Front view of Main Board-2



I/O Port -1



I/O Port -2

16 Photographs of Adapter



Front View of Adaptor



Rear View of Adaptor



SPEC